

Kappa Rev

296÷1983 kW

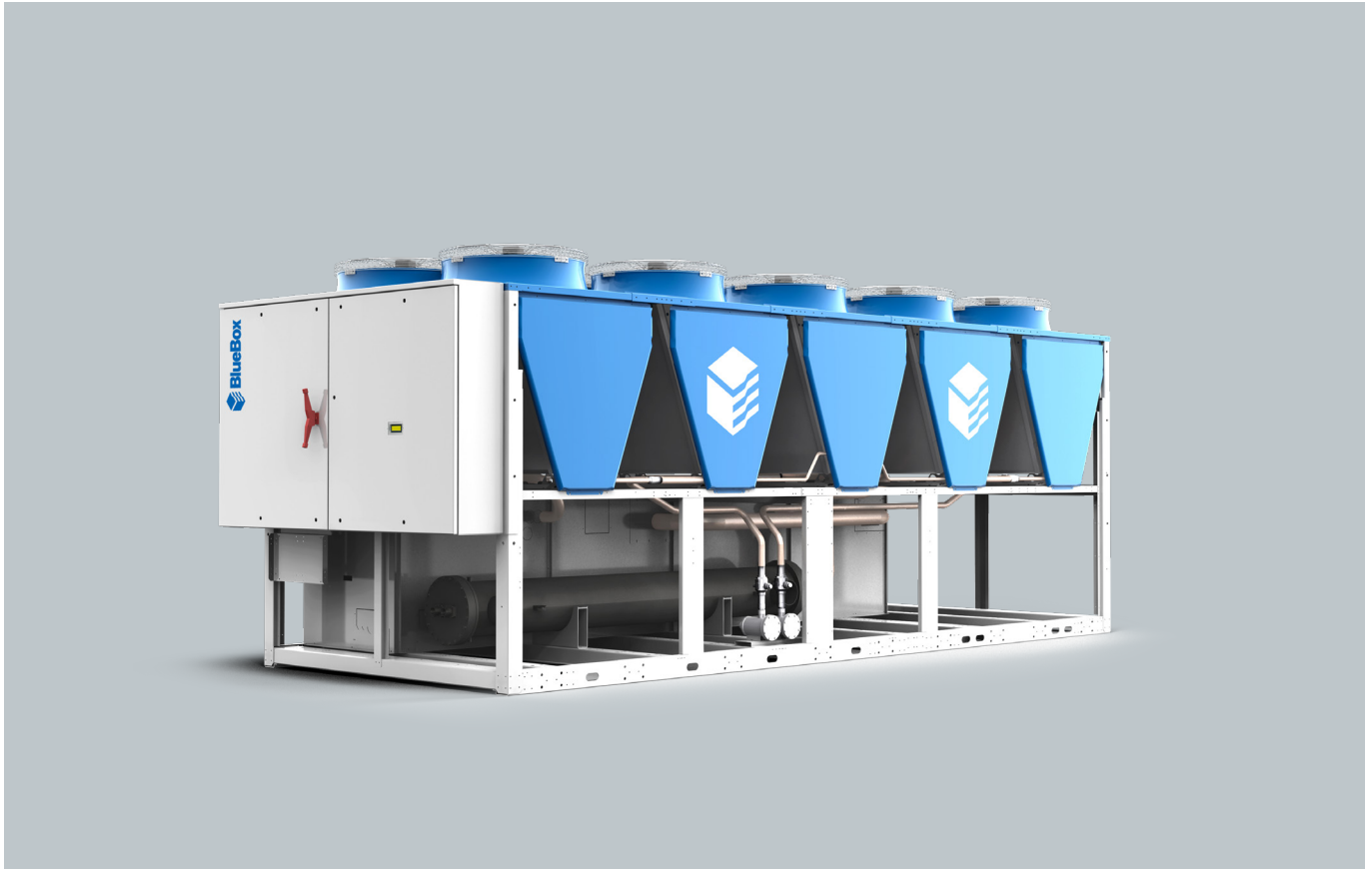

General

Modulated chillers and reversible units for large systems Wide range: multiple high efficiency combinations and low noise version

Configurations

HE: High efficiency unit

LN: low noise unit

SLN: super low noise unit

HP: reversible heat pump

DS: unit with desuperheaters

DC: unit with recovery condenser

HAT: unit for high external air temperature

HWT: unit for production of water at high temperature

Strengths

- ▶ Chiller with low refrigerant charge
- ▶ Operating in a wide range of external ambient conditions
- ▶ Intelligent management of defrost cycles: Anti-Ice Circuit
- ▶ Night Shift function for noise control (option)
- ▶ Dual power supply with automatic switching and Fast restart function (options)
- ▶ BlueThink advanced control with integrated web server. Multilogic function and Blueeye® supervision system. (options)
- ▶ Flowzer: inverter driven pumps (options)

WESTERNTM
AIRCONDITIONING
WARMTEPOMPEN

BlueBoxTM
by Swegon

Kappa Rev	
Product description	5
Versions	8
Options	8
Description of accessories	10
Refrigerant	10
Refrigerant circuit accessories	10
Fan accessories	12
Hydraulic circuit accessories	13
Electrical accessories	21
Network accessories	25
Other accessories	28
Technical specifications	31
Kappa Rev	31
Kappa Rev HE	35
Kappa Rev SLN	38
Kappa Rev SLN	40
Ecodesign	51
Electrical specifications	71
Kappa Rev	71
Kappa Rev HE - Kappa Rev SLN	73
Hydraulic modules	81
Pump data	85
User-side exchanger flow rate fields	86
Operating limits	87
Kappa Rev	87
Kappa Rev HE - Kappa Rev SLN	88
Noise levels	89
Kappa Rev	89
Kappa Rev HE	91
Kappa Rev SLN	93
Configurations that are not possible	94
Kappa Rev	94
Kappa Rev HE - Kappa Rev SLN	95
Installation advice	96
Water characteristics	96
Glycol mixtures	96
Minimum water content in the system	97
Installation site	98
Installations that require the use of treated coils	99
Aeraulic head losses and options available for the ventilating section	100
Dimensional diagrams	101
Kappa Rev	101
Kappa Rev HE - Kappa Rev SLN	103



Kappa Rev

Modulated chillers and reversible units for large systems Wide range: multiple high efficiency combinations and low noise version

PRODUCT DESCRIPTION

REFRIGERANT

Refrigerant R134a (GWP=1430) standard.

The model can be supplied with refrigerant R513A as an option.

BODY

The body is modular with a load-bearing frame, made of galvanized sheet-iron coated with polyester powder RAL 5017/7035 which makes it highly resistant to weather conditions. All screws and bolts are stainless steel.

There are yellow lifting brackets at the base of the unit to allow lifting with lifting beam.

All units are of the monoblock type with the exception of units with 4 circuits which are always made in two sections delivered separately. The two sections must be hydraulically manifolded and fed by two separate power supplies in the field (by the customer).

COMPRESSORS

Basic, HE and SLN version

For the basic, HE and SLN version units, the compressors are semi-hermetic screw compressors with continuous capacity reduction of output power from 25 to 100%, which allows the energy efficiency of the unit to be maximized in all operating conditions.

The capacity reduction of the entire unit is always continuous, from the minimum capacity reduction step, based on the number of compressors, up to 100%. Lubrication of the compressors is ensured by the pressure difference between delivery and suction.

All the compressors are fitted with check valve on delivery side, metal mesh filter on suction side and electronic protection with temperature sensors directly inserted in the windings and on the delivery pipe.

The machine is started and switched off with a forced 25% capacity reduction of each compressor and starting is of the "star-delta" type.

All the compressors are fitted as standard with crankcase heater and discharge valve.

SOURCE-SIDE HEAT EXCHANGER

The V-shaped arrangement of the coils enables them to be protected from hail and makes the unit compact. It also guarantees an increase in the air intake surface, and leaves ample space for distribution of the components of the refrigerant circuit and the hydraulic circuit.

To protect the exchangers from corrosion and ensure optimal operation of the unit, we advise following the recommendations given in the user, installation and maintenance manual for cleaning the coils. For installations within a kilometre of the coast, use of the accessory is strongly recommended Coil treated with anti-corrosion paints.

(excluding HP units)

The exchangers are made with microchannel aluminium coils. Finned pack coils with copper tubes and aluminium fins can be requested as accessory.

Thanks to continuous research in the alloys field, and sophisticated production methods, microchannel coils are made using specific aluminium alloys for the tubes and for the fins. This allows the effects of galvanic corrosion to be drastically reduced to always ensure protection of the tubes that confine the refrigerant. Tubes and fins are also subjected to SiFLUX coating processes (or equivalent) or have zinc added to further increase their corrosion resistance.

If the unit has to be installed in an environment with a particularly aggressive atmosphere, e-coated microchannel coils are available as an option. This option is strongly recommended for applications in coastal or highly industrialized areas.

The use of microchannel coils compared to conventional copper/aluminium coils reduces the total weight of the unit by about 10% and gives a reduction in refrigerant charge of at least 30%.

(only for HP units)

The exchangers are made with finned pack coils with copper tubes and aluminium fins.

At the base of each coil, there is an Anti-Ice Circuit: this prevents ice formation in the lower part of the coil and therefore allows the unit to operate even with extremely harsh temperatures and with high humidity levels.

FANS

The fans are axial fans, directly coupled to a three-phase 6-pole electric motor, with integrated thermal overload protection (Klixon®) and IP 54 protection rating.

The fan includes the shroud, designed to optimize its efficiency and reduce noise emission to a minimum, and the safety guard.

The control manages the speed of the fans through a phase cutting speed adjuster, in order to optimize the operating conditions and efficiency of the unit.

This control also has the effect of reducing the noise level of the unit: in fact, the typical conditions under which the control will be modulating the speed of the fans are those of the night, spring and autumn.

For units equipped with EC fans, the same function is carried out using the electronically commutated motor of the fans and is supplied as standard.

USER-SIDE HEAT EXCHANGER

The exchanger is a dry-expansion shell-and-tube exchanger.

It is sized to maximize the efficiency of the unit, by keeping the overall dimensions and the refrigerant charge down to a minimum.

The exchanger consists of a steel shell insulated with a shell made of closed-cell foam material, while the tube bundle is made with copper tubes.

On the hydraulic connections of the exchanger, there are also pipe taps for the differential pressure switch and wells for the temperature probes.

REFRIGERANT CIRCUIT

Each refrigerant circuit of the basic unit (cooling only) comprises:

- discharge valve for each compressor
- shut-off valve in the liquid line
- charging valves
- liquid sight glass
- replaceable solid cartridge dehydrator filter
- electronic expansion valve
- pressure transducers for reading the high and low pressure values and relevant evaporating and condensing temperatures
- high pressure switches and safety valves.

The pipes of the circuit and the exchanger are insulated with extruded closed-cell expanded elastomer that is resistant to UV rays.

Compared to the mechanical expansion valve, the electronic expansion valve allows machine stability to be reached more quickly and better superheating control to maximize the use of the evaporator in all load conditions. This also acts as shut-off valve on the liquid line, as it closes during compressor stops, so preventing dangerous refrigerant migration.

ELECTRICAL CONTROL PANEL

The electrical control panel is made in a painted galvanized sheet-iron box with forced ventilation and IP54 protection rating. The electrical control panel of the basic unit comprises:

- main disconnect switch
- fuses to protect the compressors, fans and auxiliary circuits
- compressor contactors
- fan contactors
- phase monitor
- potential-free general alarm contacts
- single potential free operating contacts
- external air temperature probe
- microprocessor controller with display accessible from the outside
- Capacitive backup battery for electronic expansion valve

All the electrical cables inside the panel are numbered and the terminal board dedicated to the customer's connections is coloured orange so that it can be quickly identified in the panel.

CONTROL BLUETHINK

Main controller functions

The microprocessor control allows the following functions:

- water temperature control, with control of the water leaving the user-side exchanger
- freeze protection
- compressor timings
- automatic rotation of compressor starting sequence
- recording of the log of all machine inputs, outputs and states
- automatic rotation of compressor starting sequence
- recording of the alarm log
- sliding defrost management
- digital input for general ON/OFF
- digital input for Summer/Winter selection (only for HP units)
- RS485 serial port with Modbus protocol
- Ethernet serial port with Modbus protocol and integrated web server preloaded web page

For further details on available functions and on displayed information, you can refer to the specific documentation of the control.

By default, the serial connections present as standard are enabled only for reading from BMS. Enabling of writing from BMS is to be requested when ordering.

Main functions of the webserver (only for units with advanced control)

As standard, the Bluethink controller integrates a webserver with a preloaded web page that is accessed via password.

The web page allows the following functions to be carried out (some of these are available only for users with advanced level rights):

- display of the main functions of the unit such as unit serial n°, size, refrigerant
- display of the general status of the machine: water inlet and outlet temperatures, external air temperature, mode (chiller or heat pump), evaporating and condensing pressures, suction and discharge temperatures
- display of the status of compressors, fans, pumps, electronic expansion valves
- display in real time of the graphs of the main quantities
- display of the graphs of logged quantities
- display of alarm log
- management of users on several levels
- remote summer winter mode selection
- remote ON/OFF
- remote set point change
- remote time band change
- remote summer winter mode selection

Human-Machine Interface

The control has a graphic display that allows the following information to be displayed:

- water inlet and outlet temperature
- set temperature and differential set points
- description of alarms
- hour meter of operation and number of start-ups of the unit, the compressors and the pumps (if present)
- high and low pressure values, and relevant condensing and evaporating temperatures
- external air temperature
- superheating at compressor suction.

Management of defrost cycles

For defrost management, the control of the unit uses a sliding intervention threshold, depending on the pressures inside the unit and the external air temperature. By putting together all this information, the control can identify the presence of ice on the coil and activates the defrosting sequence only when necessary, so as to maximize the energy efficiency of the unit.

Sliding management of the defrost threshold ensures that, as the absolute humidity of outdoor air decreases, the frequency of the defrost cycles gradually decreases because they are carried out only when the ice formed on the coil actually penalizes performance.

The defrost cycle is fully automatic and is carried out using a patented defrost system (patent n° 1335232): during the initial stage, a defrost is carried out by cycle reversal with fans stopped. When the frost on the coil has melted sufficiently, reverse ventilation is activated, that is, with air flow in the opposite direction to that of normal operation, so as to facilitate the ejection of condensed water and detached ice. When the coil is clean, ventilation is reversed again and the unit resumes operation in heat pump mode.

The combination of the sliding intervention threshold and the patented defrost system allows the number and duration of defrost cycles to be optimized and reduced to the minimum.

TESTING

All the units are factory-tested and supplied complete with oil and refrigerant.

CONTROLS AND SAFETY DEVICES

All the units are fitted with the following control and safety components:

- high pressure switch with manual reset
- high pressure safety device with automatic reset and limited tripping managed by the controller
- low pressure safety device with automatic reset and limited tripping managed by the controller
- high pressure safety valve
- antifreeze probe at outlet of each evaporator
- water differential pressure switch installed at the factory
- overtemperature protection for compressors and fans

VERSIONS

Alongside the basic version of the unit, there are various versions that differ in efficiency and noise levels.

Kappa Rev HE

The HE version unit uses oversize coils, in order to increase the ratio between exchange surfaces and capacity of the compressors. This allows all models to achieve Eurovent Class A for both EER and COP and consequently also high ESEER values.

Kappa Rev SLN

The SLN version unit uses a soundproofed compressor compartment (see description of the /LN option), oversize coils compared to the standard efficiency unit and fans with speed adjuster and reduced air flow rate. The speed reduction of the fans is such that, under nominal operating conditions, the air flow rate and noise level are lower than those of the basic version of the unit. In any case, the speed adjuster allows rotation of the fans at maximum speed when external air temperature conditions are particularly critical so as to guarantee the same operating limits as the HE version.

OPTIONS

/HP: reversible heat pump

In addition to the set-up of a chiller only unit, /HP units comprise (for each refrigerant circuit):

- 4-way reversing valve
- suction separator
- fluid accumulator
- second electronic expansion valve
- Anti-Ice Circuit at the base of each coil

Summer / winter switching can be made from the control keypad, digital input or BMS (requires write enable).

/DC: unit with total recovery condenser

In addition to the set-up of a chiller only unit, /DC units comprise:

- a heat recovery condenser for recovering 100% of the condensation heat on each refrigerant circuit. The exchanger is a brazed plate heat exchanger; for multi-circuit units, the heat exchangers are to be manifolded outside the unit (by the customer)
- temperature probe at the inlet of each recovery exchanger
- liquid receiver for each refrigerant circuit with system for emptying the refrigerant from the condensing coil
- potential free contact in the electrical control panel for activation of recovery.

When required by the system, through the closing of a contact, the control automatically manages activation of recovery. Recovery management is carried out through a control on the temperature of the return water. The control also automatically manages safety deactivation of recovery if the condensing pressure becomes too high, and changes to using the condensing coils.

This option is not available for /HP units

/DS: unit with desuperheater

In addition to the set-up of a chiller only unit, /DS units comprise (for each refrigerant circuit) an exchanger for condensation heat recovery of up to 20% (depending on size, version and operating conditions), placed in series with the condensing coils. The exchanger is a braze-welded plate heat exchanger. For multi-circuit units, the exchangers are to be manifolded outside the unit (by the customer).

To maximize the use of the accessory and optimize machine operation, combination with the speed adjuster of the fans or with the EC fans is recommended.

This option is also available for /HP units, but in this case, in the installation, it must have provision for shutting off the recovery water circuit during operation in heat pump mode to avoid taking power from the user-side heat exchanger.

Two illustrative graphs are shown below in which, as the ambient temperature changes, (T_{air}) and as the temperature of the water leaving the heat recovery heat exchanger changes, ($T_{w,out DS}$), the percentage of recovered heat is shown as an indication (Recovery ratio).

The percentage of recovered heat is calculated as the ratio between recovered thermal power to the desuperheater and the thermal power released by the condenser under nominal conditions, that is, evaporator inlet/outlet water temperature 12/7°C.

In the following graphs, a constant temperature delta of 5°C between water inlet and outlet at the heat recovery heat exchanger has been considered.

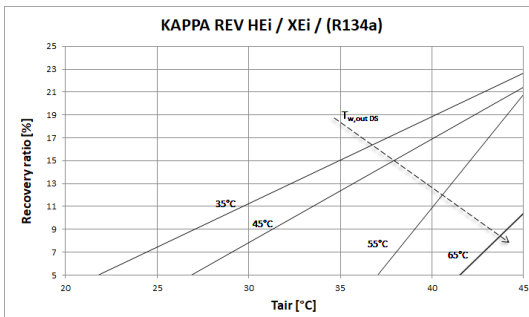
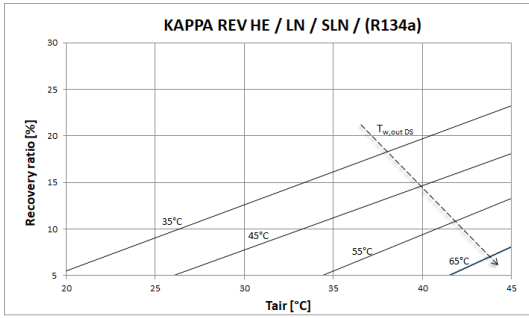

To maximize the use of the accessory and optimize machine operation, combination with the speed adjuster of the fans or with the EC fans is recommended.

/LN: silenced unit

In the unit with /LN option, all the compressors are enclosed in a compartment that is fully soundproofed with sound absorbing material and soundproofing material.

/HAT: unit for high external air temperatures

The unit fitted with this accessory adopts an electrical control panel made using specific components to withstand high temperatures, special cables and oversize protection parts.

The accessory enables the unit to work with external air temperatures of over 46°C as indicated in the section on operating limits.

With this accessory, operation is guaranteed with external air temperature up to 52°C.

For higher temperatures up to about 55°C, a set-up with air conditioning of the electrical control panel is necessary; the unit works in capacity reduction mode. The feasibility of this set-up must be assessed: please contact our sales department.

/HWT: unit for high temperatures of produced water

Units with /HWT option use compressors with oversize electric motor for production of water at high temperature. This option is available for /HP units or for cold only units with /DC option.

HYDRAULIC MODULES

All units can be fitted with hydraulic module in various configurations:

- /1P: hydraulic module with one pump
- /2P: hydraulic module with two pumps
- /1PS: hydraulic module with one pump and buffer tank
- /2PS: hydraulic module with two pumps and buffer tank

All the above-mentioned modules have pumps with standard discharge head.

The following are also available:

- modules /1PM, /2PM, /1PMS and /2PMS that have pumps with increased available discharge head
- modules /1PG, /2PG, /1PGS and /2PGS that have pumps suitable for operating with glycol up to 50%

Hydraulic modules with one pump have:

- one pump
- a gate valve on the delivery side of the pump
- an expansion vessel

Hydraulic modules with two pumps have:

- two pumps
- a check valve on the delivery side of each pump
- a gate valve on the outlet of the delivery manifold
- an expansion vessel

In the version with 2 pumps, these are always with one on standby while the other is working. Switching over between the pumps is automatic and is done by time (to balance the hours of operation of each one) or in the event of failure.

Hydraulic modules with tank also have:

- a gate valve at the inlet of the pump or the suction manifold
- a tank with drain valve and air valve

Refer to the table of configurations that are not possible to check for availability of specific set-ups.

DESCRIPTION OF ACCESSORIES

Some accessories may be incompatible with each other even if not expressly indicated.

Refrigerant

R513 R513A

Unit supplied with R513A refrigerant instead of R134a.

R513A is distinguished by its low environmental impact, with GWP=573. It is also a non-toxic and non-flammable fluid: A1 classification in accordance with ASHRAE; PED 2.

These characteristics facilitate the adoption of the model in the presence of any specific local requirements related to the environmental impact caused by the refrigerants. This has positive effects on transport, operation and maintenance and also on overall cost effectiveness, as regards possible taxation or restrictions on the use of refrigerants with high environmental impact.

Refrigerant circuit accessories

BK Brine Kit

This accessory is compulsory if a water temperature set point lower than +3°C is used (if the unit is provided with double set point or variable set point, the lower set point is considered).

The accessory consists of increased insulation and suitable sizing and calibration of some components.

The inlet and outlet temperatures of the user-side exchanger must be given on ordering to allow correct setting of the alarm parameters and verification of the sizing of the expansion valve.

The cooling set point can then be changed by the customer in an interval that, compared to the set point given on ordering, ranges from -1K up to the maximum temperature allowed by the above-stated operating limits.

The unit will be optimized to work at the set point temperature given on ordering. For different set points, the cooling capacity provided and the level of efficiency of the machine could decrease and move away from these conditions.

This accessory compulsorily requires the insertion of one of the options: condensing control with speed adjuster or EC fans.

DVS Double safety valve

With this accessory, instead of each individual safety valve per circuit, there is a "candelabrum" with two safety valves and a diverter valve for choosing the valve in operation. This allows the safety valves to be replaced without having to drain the machine and without having to stop it.

MAFR Pressure gauges

The operating pressures of each circuit of the unit can be displayed on the control by accessing the relevant screens. Also, the machine can be fitted with pressure gauges (two for each circuit) installed in a clearly visible position. These allow reading in real time of the working pressures of the refrigerant gas on the low pressure side and on the high pressure side of each refrigerant circuit.

RG Condensation control with fan speed adjuster

The control manages the speed of the fans through a phase cutting speed adjuster, in order to optimize the operating conditions and efficiency of the unit.

This control also has the effect of reducing the noise level of the unit: in fact, the typical conditions under which the control will be modulating the speed of the fans are those of the night, spring and autumn.

For units equipped with EC fans, the same function is carried out using the electronically commutated motor of the fans and is supplied as standard.

RIC Liquid receiver

The adoption of this accessory always guarantees correct feeding of the expansion valve even when the unit is subjected to wide external air temperature ranges.

This accessory is standard on DC and HP units.

RUBA Compressor suction valves

The valves situated on the suction side of the compressors allow the compressor to be isolated from the rest of the refrigerant circuit, so making the maintenance operations quicker and less invasive.

The compressor discharge valve is standard on all compressors

VS Liquid line solenoid valve

This accessory prevents refrigerant migration that could damage the compressor on starting.

RPR Refrigerant leak detector

With this accessory, a refrigerant leak detector is placed inside each compressor compartment. Detection of a refrigerant leak is managed by the controller through a specific alarm and display of a specific icon on the display of the controller. This alarm stops the unit.

RPP Refrigerant leak detector with automatic pump down

With this accessory, a refrigerant leak detector is placed inside each compressor compartment. Detection of a refrigerant leak is managed by the control through a specific alarm and display of a specific icon on the display of the control. For all the circuits of the unit, the alarm also starts the machine stopping procedure with pump down, confining all the refrigerant in the coils.

The accessory includes the capacitive backup battery.

The accessory can be applied only to units in LN or SLN set-up.

Fan accessories

VEC EC fans

With this accessory, EC fans, with electronically commutated brushless motor, are used for the ventilating section. These guarantee very high efficiency levels for all working conditions and allow a 15% saving on the power absorbed by each fan working at full capacity.

Also, through a 0-10V analogue signal sent to each fan, the microprocessor carries out condensation/evaporation control by continuous adjustment of the air flow rate as the external air temperature changes, with a further reduction in electrical absorption and noise emission.

For further details, see the dedicated chapter: "Aeraulic head losses and options available for the fan section".

VEM Oversize EC fans

The increased EC fans allow to obtain the same benefits as EC fans and in addition allow to have a residual useful head of about 100Pa.

For further details, see the dedicated chapter: "Aeraulic head losses and options available for the fan section".

RECP Pressure recuperator

Normally, the air ejected by the fan has a high speed and this manifests itself as kinetic energy that is dissipated into the environment.

The pressure recuperator is a passive element situated on the ejection duct of each individual fan designed to allow better conversion of kinetic energy into static pressure, which manifests itself as a higher pressure generated by the fan.

This higher pressure can have at least two possible applications:

- For the same fan speed, the pressure recuperator allows an increase of about 50Pa in the available pressure of the ventilating section to be obtained. This can be useful for overcoming the head losses that may be present in specific installations. The increase in available pressure is to be considered in addition to the increase that can already be obtained with the application of oversize EC fans
- for the same pressure differential on the air, the pressure recuperator allows the same air flow rate to be obtained with a lower number of revolutions of the fan. This automatically produces a reduction of up to 3 dB(A) in the noise emission of the unit and a reduction in the absorption of the fan, with an immediate increase in the overall efficiency of the unit.

The reduction in total sound power varies depending on the model and version of the unit as it is related to the incidence of noise generated only by the fan section on the total noise emitted by the unit.

For SLN units, which already work with a reduced air flow rate, application of the pressure recuperator has a limited or negligible noise reduction effect.

To allow optimization of the performance of the accessory, combination with the speed adjuster or EC fans is necessary. In this last case, the higher efficiency of the EC fans (especially when operating at low speed) is added to the performance improvement generated by the pressure recuperator.

The accessory is supplied separately from the unit on one or more pallets and it must compulsorily be installed (by the customer) before the first start-up of the machine.

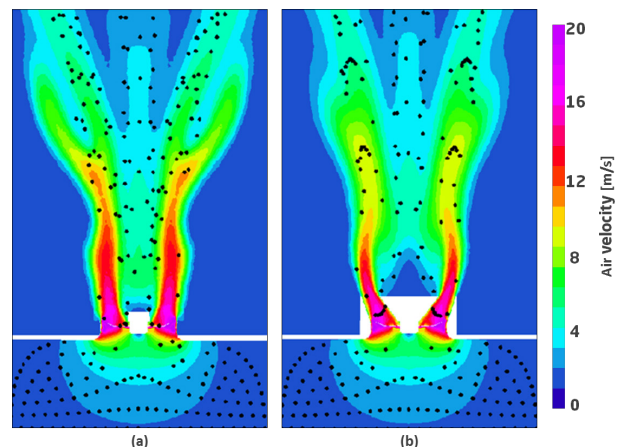
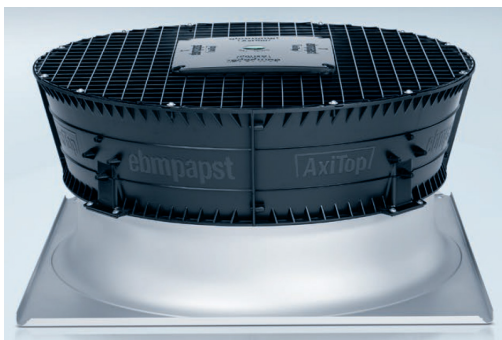

(a) fan only;

(b) fan with pressure recuperator

Hydraulic circuit accessories

FVP FLOWZER VP - Inverter for manual pump adjustment

The accessory consists of inserting an inverter in the machine to manually adjust the speed of the pump (or pumps) in order to calibrate the pump flow rate on the head losses of the system.

This accessory is to be combined with one of the integrated hydraulic modules that can be selected for the unit. Units equipped with integrated hydraulic module allow a certain level of available discharge head (point A) to be obtained under nominal flow rate conditions Q_d .

But the actual head loss level of the system (e.g. characteristic curve R') normally causes the pump to find a different equilibrium point (point B), with a flow rate Q_r higher than Q_d .

In this condition, in addition to having a different flow from the nominal one (therefore also a different temperature jump), there is also a greater absorption of electric power from the pump itself.

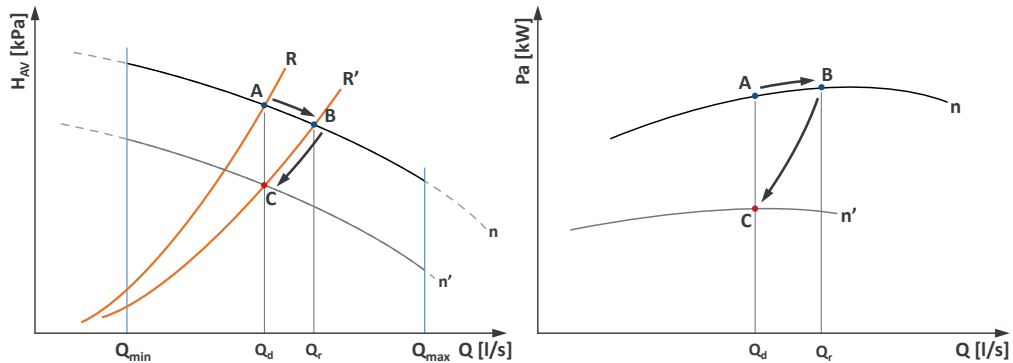

The use of the Flowzer allows the pump speed to be set manually (e.g. at speed n' instead of n) to obtain the design water flow rate and thermal gradient (point C). Once the adjustment procedure has been carried out, the pump will always work at a fixed flow rate.

The adoption of the VP Flowzer allows to considerably reduce the electrical power consumption of the pump with a consequent energy saving. By way of example, a reduction in the flow rate of 10% leads to a reduction in power consumption of around 27%.

FVD FLOWZER VD - Transducer for automatic adjustment

Flowzer VD requires two pressure transducers to be installed in the machine. Through these transducers, the inverter can gauge the actual pressure at the ends of the system and it can automatically adapt the pump speed to obtain a set available discharge head value. Flowzer VD must be combined with Flowzer VP. This accessory therefore allows a constant pressure system to be achieved.

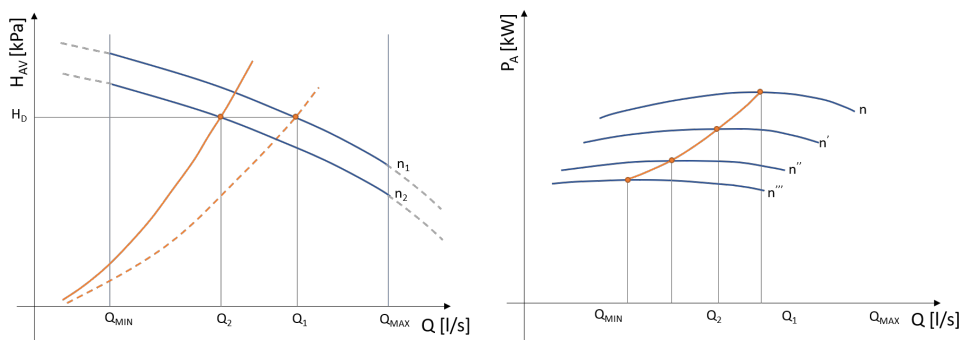

With the Flowzer VD, the customer can set, directly on the inverter, the available discharge head value H_d that the unit must maintain. As can be seen from the graph as the user request decreases, the resistant curve of the plant moves to the left, consequently the inverter reduces the speed of the pump in order to maintain the useful head necessary for the unit. With this system a significant reduction in electrical power is achieved. The customer will have to check that, in minimum flow rate conditions (that is, with the maximum number of user points closed), this is always higher than or equal to the minimum flow rate allowed by the unit.

This accessory is useful when the total head losses of the circuit are slightly variable or when they change depending on the seasons (for example, some user points are active only during summer operation and not during winter operation).

The use of this accessory also allows the pump speed to be adapted to possible fouling of the filter on the hydraulic circuit.

FVF **FLOWZER VFPP – Kit for variable flow rate primary circuit pump with bypass valve included**

Bluethink solution for a variable flow rate system, consisting solely of a user-side primary circuit.

Flowzer VFPP includes:

- a pressure transducer installed at the ends of the user-side exchanger (Δp_e)
- a dedicated control system, installed at the factory in the electrical control panel of the unit (SC)
- a modulating bypass valve with servo-motor supplied separately with it (Vbp), supplied loose (installation by the customer)
- two system pressure transducers (Δp_p) supplied separately (installation by the customer)

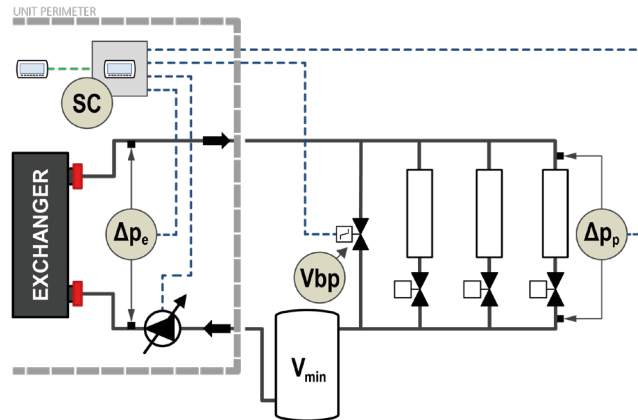

It is obligatory for the option to be combined with the Flowzer VP (inverter) and with one of the hydraulic modules that can be selected for the unit. The accessory is not compatible with Multilogic. Please contact our sales department for further details.

The unit must include the advanced Bluethink controller, just one heat exchanger on the user side and a minimum capacity step of 25% or less.

The option offers a complete default package to guarantee simple selection, purchasing and commissioning.

Flowzer VFPP has the advantage of:

- implementing an innovative design, which is alternative to the classic system based on fixed flow-rate primary circuit plus secondary circuit
- being ideal for new or entirely redesigned systems, especially for comfort applications
- having a variable flow system, with maximum energy saving
- simplifying the layout of the user circuit
- limiting the capex of the system
- performing a reliable check

The Flowzer VFPP system controller uses an advanced algorithm that enables prevention of unnecessary waste of energy and hunting by the inverter and the bypass valve.

The capex of the system is also reduced thanks to:

- single inverter + pumping module, integrated in the unit
- small internal footprint, due to the simplified layout

The operating principle can be summarized as follows:

- Flowzer VFPP carries out constant control of the discharge head
- the controller modulates the pump speed according to the signal detected by the system transducers Δp_p
- as the demand from the system goes down, the pump speed will be reduced.
- the pump speed can be reduced until it reaches the minimum allowed flow rate on the heat exchanger of the unit
- this flow rate is indirectly monitored through the losses detected by the differential pressure transducer Δp_e
- When the minimum allowed flow rate threshold is exceeded, the control system will open the bypass valve V_{bp} to recirculate the flow rate that is not required by the system, but is necessary to guarantee the minimum flow rate to the heat exchanger.

In the required minimum load condition (that is, with all system terminals switched off) the necessary minimum volume (V_{min}) must be ensured by the relevant tank to be installed between the unit and the separator or the bypass pipe.

The bypass valve V_{bp} is controlled through a 0-10 V signal and must therefore be installed within 30 m of the unit.

The pressure transducers of the system Δp_p provide a 4-20 mA signal and require two 1/4" female fittings. These transducers must be installed within 200 m of the unit, near the system terminal that is affected by the highest line head losses or in any case in a position where it is possible to measure an adequate pressure value.

Further details can be found in the relevant manual.

Bypass valve diameter	Kappa Rev	Kappa Rev HE Kappa Rev SLN
3"		
4"	33.2	33.2
	35.2	35.2
	37.2	37.2
	40.2	40.2
	43.2	43.2
	51.2	51.2
5"	54.2	54.2
	58.2	58.2
	67.2	67.2
	73.2	73.2
	80.2	80.2
6"	85.2	85.2
	90.2	90.2
	95.2	95.2
	100.2	100.2
	105.2	105.2
	115.2	115.2
2 x 5"	120.2	120.2
	130.2	
	140.3	
	150.3	
	160.3	

FVPS FLOWZER VPS – Kit for variable flow rate pump with temperature sensors

Bluethink solution for a variable flow rate system, consisting of a primary circuit plus secondary circuit.

Flowzer VPS includes:

- a differential pressure transducer, installed at the factory at the ends of the user-side heat exchanger of the unit (Δp_e)
- a dedicated control system, installed at the factory in the electrical control panel of the unit (SC)
- two system temperature sensors (T) - supplied separately; installation by the customer

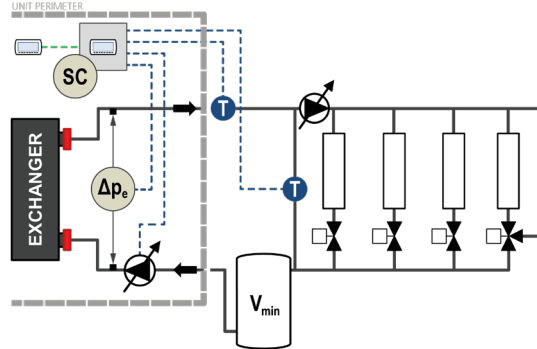

It is obligatory for the option to be combined with the Flowzer VP (inverter) and with one of the hydraulic modules that can be selected for the unit. The accessory is not compatible with Multilogic. Please contact our sales department for further details.

The unit must include the advanced Bluethink controller, just one heat exchanger on the user side and a minimum capacity step of 25% or less.

The option offers a complete default package to guarantee simple selection, purchasing and commissioning.

Flowzer VPS has the advantage of:

- being ideal for renovations of existing systems, especially for comfort applications
- achieving a complete variable flow system, with maximum energy saving
- implementing a flexible design, e.g. for scalable or multi-zone systems

The maximum energy saving is achieved thanks to the advanced algorithm, which prevents hunting by the inverter and balances the pump speed and the recirculation flow rate to a minimum.

With refurbishments, the system's capex is limited to the unit and its commissioning.

The dimensions of the inverter of the unit and of the pump module can be favoured by the low design discharge head of the primary circuit.

The operating principle can be summarized as follows:

- Flowzer VPS performs a smart check of the flow rate in the primary circuit and balances it with the flow rate in the secondary circuit.
 - the system controller modulates the pump speed according to the condition detected by the system sensors T
 - if the system terminals are switched off, the flow rate of the secondary circuit will decrease; therefore the direction of flow is detected indirectly as temperature difference by the system sensors through the separator or the bypass pipe
 - The check thus contributes to reducing the speed of the primary pump until the min. flow threshold in the heat exchanger of the unit is exceeded.
 - this flow rate is indirectly monitored through the losses detected by the differential pressure transducer Δp_e
- In the required minimum load condition (that is, with all system terminals switched off) the necessary minimum volume (V_{min}) must be ensured by the relevant tank to be installed between the separator or the bypass pipe.

The temperature sensors of the system T provide a 4-20 mA signal and require 1/2" female fittings.

Further details can be found in the relevant manual.

RA Antifreeze heater

These are electric heaters inserted on the user-side heat exchanger, on the pumps and in the tank (depending on the configuration of the machine) to prevent damage to the hydraulic components due to ice formation during periods when the machine is stopped.

Based on normal operating conditions and the percentage of glycol in the system, an appropriate "antifreeze alarm" temperature is set in the control. When a temperature that is 1K higher than the antifreeze alarm threshold is detected at the outlet from the exchanger, the pump (if present) and the antifreeze heaters are switched on. If the temperature of the outgoing water reaches the antifreeze alarm threshold, the compressors are stopped, keeping the heaters and the pumps active, and the general alarm contact of the machine is activated.

VSIW Water-side safety valve

With this accessory, a safety valve is inserted in the hydraulic circuit of the unit: when the calibration pressure is reached, the valve opens and, by discharging (to be routed by the customer), prevents the system pressure from reaching limits that are dangerous for the components present in the system. The valves have positive action, that is, performance is guaranteed even if the diaphragm deteriorates or breaks.

FLUS Flow switch (instead of the water differential pressure switch)

As an alternative to the differential pressure switch (standard flow sensor), it is possible to request the paddle flow switch as accessory. This detects when there is no water flow to the user-side exchanger and sends a signal to the control of the unit that will stop the compressors to prevent damage to the exchangers.

Application of this accessory is compulsory for units that use non-glycol water and work with a yearly cycle where external air temperatures are zero or below.

The flow switch is supplied loose (installation by the customer) and replaces the water differential pressure switch (standard).

FVDE FLOWZER VDE - Differential transducer for automatic pump adjustment at a constant flow value

Flowzer VDE requires a differential pressure transducer to be installed in the machine. Through this transducer, the inverter can gauge the actual pressure at the ends of the heat exchanger installed in the machine and it can automatically adapt the pump speed for a constant flow value under all conditions. Flowzer VDE must be combined with Flowzer VP.

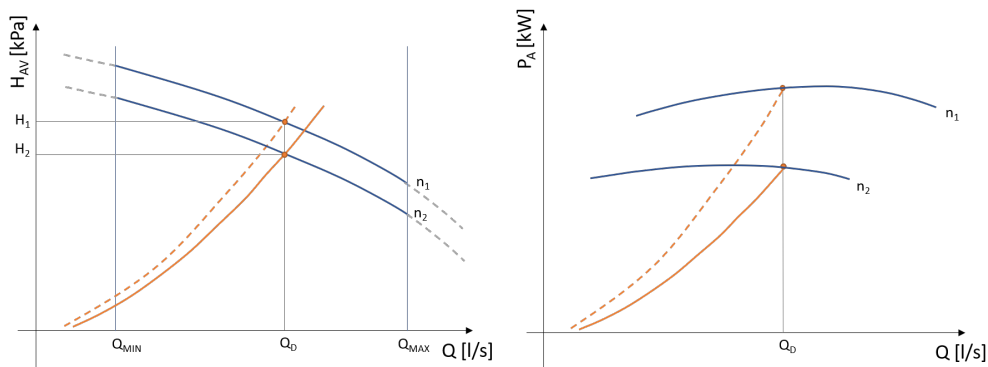

Flowzer VDE is used to automatically adjust the pump speed. As the graph shows, the inverter trips and increases the pump speed if a different condition occurs which would cause an undesired drop in the flow rate (e.g. operation of an external dry cooler). This is a more accurate solution than the VP option alone as it always provides for the water flow (Q_D) required by the design conditions.

HFx HYZER E VFPP function

The HYZER E VFPP function combines the Multilogic function, which is designed to manage multi-machine systems, with the FLOWZER VFPP control for variable flow systems.

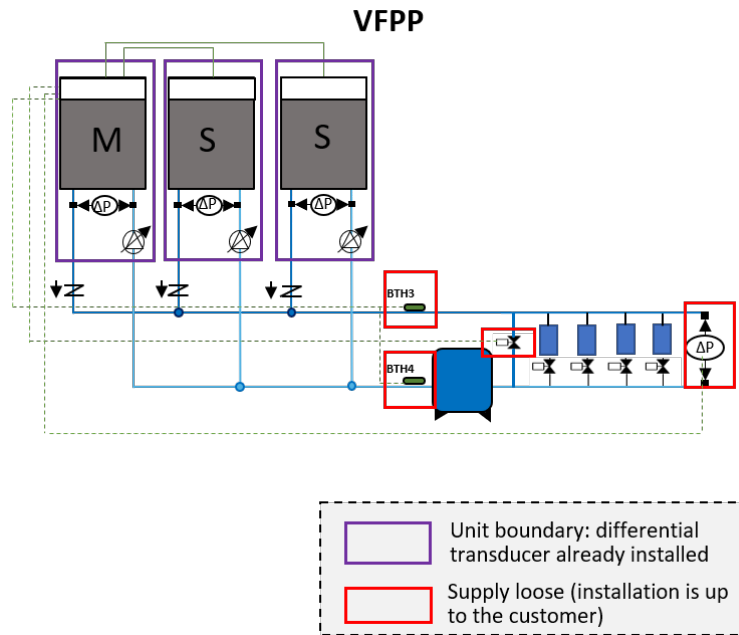

It is obligatory for the option to be combined with the Flowzer VP (inverter) and with one of the hydraulic modules that can be selected for the unit.

The unit must include the advanced Bluethink controller, just one heat exchanger on the user side and a minimum capacity step of 25% or less.

Units operate according to the Master/Slave logic that is typical of a Multilogic system. For additional details, please refer to the FMx option.

VFPP control requires the installation on the machine of a differential transducer at the ends of the user-side heat exchanger in order to keep the flow rate in the system within a specific min. value allowed.

For additional details on the FLOWZER VFPP logic, please refer to the dedicated FVF option.

The networked units may be of different types, and the same observations as for the Multilogic option apply:

- if there are both chiller units and heat pumps in the network, the Master unit must obligatorily be one of the HP units;
- if there are both free-cooling and non free-cooling units in the network, the Master unit must obligatorily be one of the free-cooling units.

The HYZER E function requested with the unit can be:

- **HF0:** HYZER E VFPP function for Slave units;
- **HF2:** HYZER E VFPP function for the Master unit in order to manage up to 2 Slave units;
- **HF6:** HYZER E VFPP function for the Master unit in order to manage up to 6 Slave units.

If you need to connect more than 6 slaves (up to 31), you can ask for a quotation from our sales department.

For the slave units, the accessory requires:

- programming of the unit as slave of a system of machines in Multilogic network

For the master units, the accessory requires:

- programming of the unit as master of a system of machines in Multilogic network
- entering of the parameters necessary for connection with the individual slave units
- installation in the electrical control panel of a network switch to allow the units to be connected in a LAN network.
- the supply of 2 temperature probes to be positioned on the delivery and return manifold for system thermoregulation (supplied with the system - installation and wiring by the customer);
- the supply of two pressure transducers (supplied with the system - installation and wiring by the customer) to be installed near the system terminal that is affected by the highest head losses in the line or in any case in a position where it is possible to measure an adequate pressure value.
- The option also includes the supply of a bypass valve controlled by a 0-10 V signal, which must be selected in function of the system capacity. Please refer to the VBx options for correct selection.

The connection between the master unit and the slave units made with a CAT cable. 5E/UTP (prepared by the customer) with RJ45 connectors. Maximum cable length 100m.

For further details, please refer to the controller manual.

The connection between the master unit and the slave units made with a CAT cable. 5E/UTP (prepared by the customer) with RJ45 connectors. Maximum cable length 100m.
For further details, please refer to the controller manual.

VBx VFPP bypass valve for HYZER E

The option is supplied with the bypass valve, which is selected according to the system capacity.
This option must be selected with either the "HYZER E VFPP function for Master unit to manage up to 2 Slave units" or "HYZER E VFPP function for Master unit to manage up to 6 Slave units".

	System capacity range**	Quantity	Diameter	Qmax**
	kW	-	in	m ³ /h
S_A	<240	1	2 1/2"	41.3
S_B	240÷335	1	3"	57.6
S_C	335÷570	1	4"	98
S_D	570÷850	1	5"	146.2
S_E	850÷1250	1	6"	215
S_F	1250÷1700	2	2 x 5"	2 x 146.2
S_G	1700÷2500	2	2 x 6"	2 x 215

** values based on a 5 °C temperature difference between the delivery and the return temperature

HSx HYZER E VPS function

The HYZER E VPS function combines the Multilogic function, which is used to manage multi-machine systems, with the FLOWZER VPS control for variable flow systems.

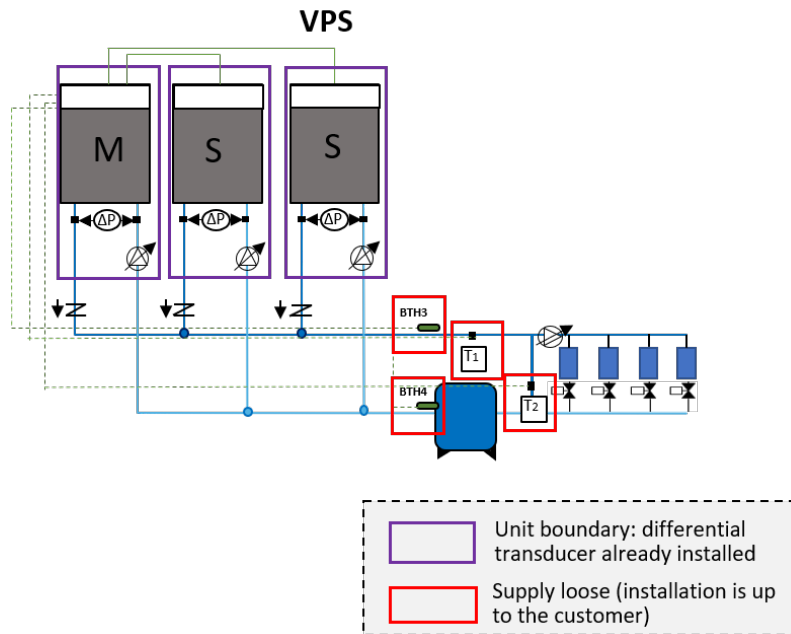

It is obligatory for the option to be combined with the Flowzer VP (inverter) and with one of the hydraulic modules that can be selected for the unit.

The unit must include the advanced Bluethink controller, just one heat exchanger on the user side and a minimum capacity step of 25% or less.

Units operate according to the Master/Slave logic that is typical of a Multilogic system. For additional details, please refer to the FMx option.

VPS control requires the installation on the machine of a differential transducer at the ends of the user-side heat exchanger in order to keep the flow rate in the system within a specific min. value allowed.

For additional details on the FLOWZER VPS logic, please refer to the dedicated FVPS option.

The networked units may be of different types, and the same observations as for the Multilogic option apply:

- if there are both chiller units and heat pumps in the network, the Master unit must obligatorily be one of the HP units;
- if there are both free-cooling and non free-cooling units in the network, the Master unit must obligatorily be one of the free-cooling units.

The HYZER E function requested with the unit can be:

- **HS0:** HYZER E VPS function for Slave units;
- **HS2:** HYZER E VPS function for the Master unit in order to manage up to 2 Slave units;
- **HS6:** HYZER E VPS function for the Master unit in order to manage up to 6 Slave units.

If you need to connect more than 6 slaves (up to 31), you can ask for a quotation from our sales department.

For the slave units, the accessory requires:

- programming of the unit as slave of a system of machines in Multilogic network

For the master units, the accessory requires:

- programming of the unit as master of a system of machines in Multilogic network
- entering of the parameters necessary for connection with the individual slave units
- installation in the electrical control panel of a network switch to allow the units to be connected in a LAN network.
- the supply of 2 temperature probes to be positioned on the delivery and return manifold for system thermoregulation (supplied with the system - installation and wiring by the customer);
- the supply of 2 temperature probes to be installed on the delivery manifold and on the bypass branch, which are typical of VPS control (supplied with the system - installation and wiring by the customer).

The connection between the master unit and the slave units made with a CAT cable. 5E/UTP (prepared by the customer) with RJ45 connectors. Maximum cable length 100m.

For further details, please refer to the controller manual.

PVX Variable flow setup for HYZER X

The dedicated HYZER X controller is designed to manage the different units, devices and components that make up a hydronic system.

Systems featuring this controller require that the PVX option be installed at the ends of the user-side heat exchanger of a differential pressure transducer so that the machine is set up for variable flow rate control.

This option is mandatory in all units making up the system.

For additional information on the product HYZER X, please refer to the specific technical catalogue.

VIX Shut-off valves for systems with external pumps for HYZER X

Systems featuring the HYZER X controller enable the selection of the shut-off valve used in systems that have an external pumping unit.

The option is always supplied separately from the unit and is for installation by the customer.

FLMX User-side flow meter for HYZER X

Systems featuring the HYZER X controller enable the selection of the flow meter option to calculate the flow rate and the performances of the units.

Two flow meters are supplied together with multifunctional machines that need to be installed on the cold and the hot circuit of the unit (installation by customer).

Electrical accessories

ARU Stopping of the unit due to temperatures below the operating limit

With this accessory, it is possible to set the unit so that the controller switches off the compressors when the unit is operating in heat pump mode and the external air temperature falls below a minimum set limit: this will prevent the unit from going into low pressure alarm, so avoiding having to manually restart the machine. When the external air temperature returns above the set threshold temperature, the unit will automatically resume operation without it being necessary to do anything.

For units equipped with integrated pump, the pump will always be kept running so as to prevent ice formation and ensure correct reading of the temperature and antifreeze safety probes at all times.

The stopping temperature must be set based on the set point temperature and in accordance with what is allowed by the operating limits of the machine.

The same function can be used to set an external air temperature below which to use an alternative heat source because it is more efficient or economically more advantageous.

With the default programming, the limit that considers a production of outgoing water at 45°C is set, therefore:

- -7°C for standard units
- -10°C for /HE and /SLN units.

CSP Set point compensation depending on external air temperature

For units fitted with this accessory, the set point of the unit is set so that it can vary between two values, a maximum and a minimum, depending on the external air temperature. The compensation ramp and the maximum and minimum values of the set point can be changed by the user.

Unless otherwise specified in the order, the controller will be set to implement a positive compensation logic according to the temperatures shown in the following diagrams:

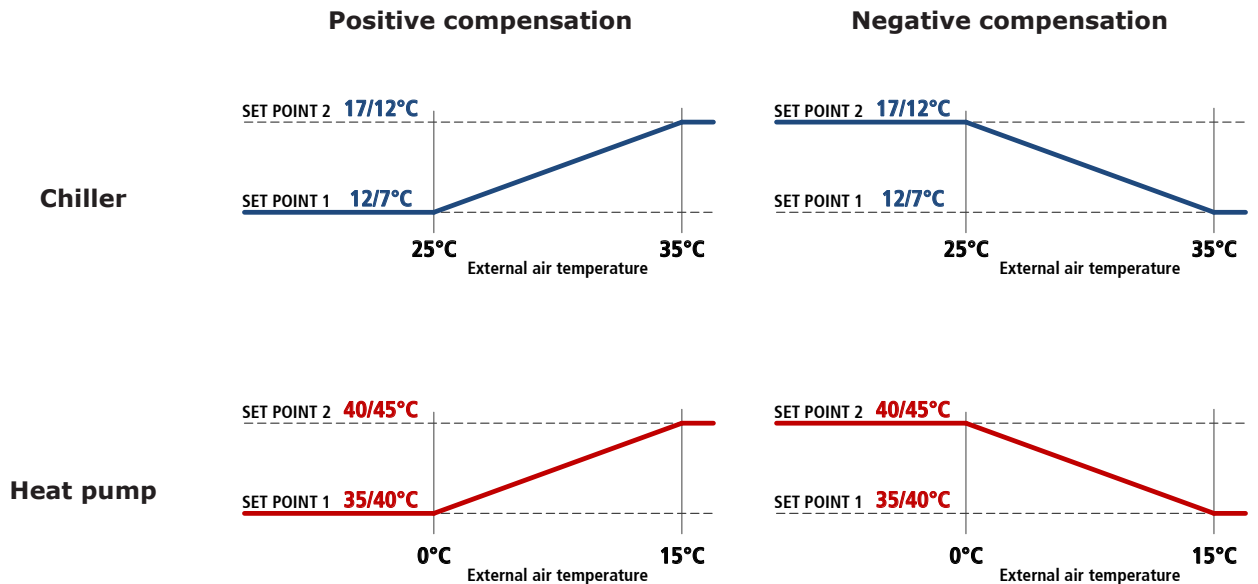

DAA Double power supply with automatic switching

A motor-driven automatic switch to which to connect two separate power supply lines (for example, one from the mains power line and one from the uninterruptible power supply unit) is installed in the electrical control panel of the unit.

The switching from one line to another is automatic and obligatorily requires passing through the OFF position. When this accessory is requested, the power supply of the unit must compulsorily include neutral.

DAM Double power supply with manual switching

A manual switch to which to connect two separate power supply lines (for example, one from the mains power line and one from the uninterruptible power supply unit) is installed in the electrical control panel of the unit.

The switching from one line to another is manual and obligatorily requires passing through the OFF position.

FARE Fast Restart

The Fast Restart accessory enables the controller to carry out a fast restart of the unit following a blackout, in order to reduce machine down times to a minimum.

This accessory requires the provision of a power supply line dedicated to the controller (uninterruptible power supply unit installed by the customer) and a maximum and minimum voltage relay in the electrical control panel. In this way, the controller of the unit will always remain powered even during a blackout.

Once the main power supply returns after a blackout, the starting of the first compressor takes place within 60 seconds and the full capacity of the unit is reached in about 180 seconds (a time that depends on the number of compressors and the instant load level).

In order to protect component service life, the controller may carry out the Fast Restart procedure no more than 3 times in an hour and 5 times in one day.

Also, to make it easier to carry out any maintenance on the power supply line dedicated to the controller, there is a selector switch inside the electrical control panel to allow the controller to be powered directly from the main power supply of the machine.

RMMT Maximum and minimum voltage relay

This accessory constantly monitors the voltage value and the unit's power supply phase sequence. If the supply voltage does not fall within the set parameters or there is a phase reversal, an alarm is generated that stops the machine to prevent damage to its main parts

With this accessory, automatic circuit breakers are installed instead of fuses for the protection of auxiliary loads. Also, the same accessory uses automatic circuit breakers with adjustable thermal overload protection to protect the compressors.

IACV Automatic circuit breakers

With this accessory, automatic circuit breakers are installed instead of fuses for the protection of auxiliary loads. Also, the same accessory uses automatic circuit breakers with adjustable thermal overload protection to protect the compressors.

LIID Limitation of the current absorbed by digital input

When this accessory is requested, a digital input is prepared in the terminal board to activate the forced capacity reduction of the unit to a set fixed level.

This accessory is useful when there is a need to necessarily limit the power absorbed by the unit as regards particular conditions.

We point out that, in some conditions (for example, during defrosting, oil return cycles or hourly compressor rotation procedures), the controller could force the unit to operate at full capacity for limited periods of time.

LIRA Absorbed current limitation with measurement of absorption

For the unit equipped with this accessory, it is possible to set, directly in the control, a maximum current that can be absorbed by the machine. The control instantly checks the absorptions, through an amperometric transformer, and, in case of need, applies a dynamic forced capacity reduction able to always keep the absorbed current below the set threshold.

NSS Night Shift System

This accessory is applied to high efficiency /LN version units with speed adjuster or to SLN units.

In the day time slot, which is normally the one with the highest heat load, priority is given to efficiency and therefore the machine works with a fan control curve that maximises the EER. In this time slot, therefore, the unit is a high efficiency low noise machine (equivalent to HE/LN)

In the night time band (or in any case from time band decided by the customer), the priority changes to limiting the noisiness of the machine and therefore the controller carries out an adjustment of the control ramp of the condensing fans, thereby reducing the air flow rate and consequently the noise emission level. So, in this time band, the unit is a super low noise machine (equivalent to SLN).

In any case, if there is a need for additional cooling capacity, the controller will manage the demand, if necessary, by accelerating the fans and keeping condensation within the correct operating limits.

The time slots can be set from the control depending on installation requirements.

When the unit is working in heat pump mode, in order to maximise the COP and to obtain the widest possible operating limits, the control of the unit forces the fans to the maximum speed also during the night time bands.

RE1P Relay for management of 1 external pump

This accessory can be requested for units without pumps and allows a pump outside the machine to be controlled.

RE2P Relay for management of 2 external pumps

This accessory can be requested for units without pumps and allows two pumps outside the machine to be controlled with a running/stand-by logic by implementing a rotation on the hours of operation.

The two pumps are controlled by two separate relays.

RIF Power factor correction to $\cos\phi \geq 0.95$

With this accessory, an electrical control panel (IP54 protection rating), containing power factor correction capacitors to make the $\cos\phi$ of the unit greater than or equal to 0.95, is supplied with the unit. The capacitors should be connected (by the customer) to the electrical control panel of the unit in the specially prepared terminal board.

Besides reducing the absorbed reactive power, the use of this accessory also allows the maximum absorbed current to be lowered.

SETD **Double set point from digital input**

The accessory allows you to preset two different operating set points and manage the change from one to the other through a digital signal.

The set point temperatures must be specified when ordering. For optimization of the unit, reference will be made to the lower set point in chiller mode and the higher set point in heat pump mode.

Unless otherwise specified in the order, the controller will be set at the factory with the following temperatures:

- in chiller mode, set point 1 to 7°C and set point 2 to 12°C
- in heat pump mode (only for HP units) set point 1 to 45°C and set point 2 to 40°C

SEVF **Variable set point with remote signal cold circuit**

The accessory allows the set point to be varied continuously between two preset values, a maximum and a minimum, depending on an external signal that can be of the 0-1V, 0-10V or 4-20mA type.

The set point temperatures and the type of signal to use for the adjustment must be specified when ordering. For optimization of the unit, reference will be made to the lowest set point.

Unless otherwise specified in the order, the controller will be set at the factory with 0-10V analogue input and with the following temperatures:

- 0V will correspond to a set point of 7°C
- 10V will correspond to a set point of 12°C

SOFT **Electronic soft-starter**

Screw compressors (excluding inverter-controlled ones) are switched on using star-delta starting since this method allows very small effective average inrush currents to be obtained, but, as can be seen in the following diagrams, the connection change generates current peaks lasting a few ms.

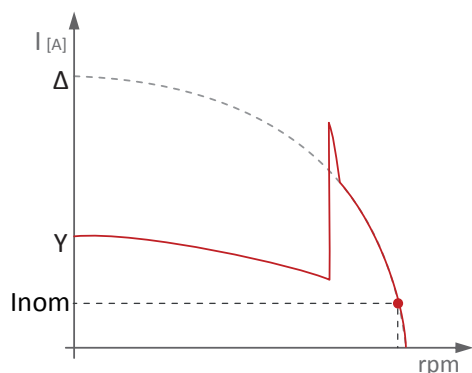

Current trend without accessory Electronic soft-starter

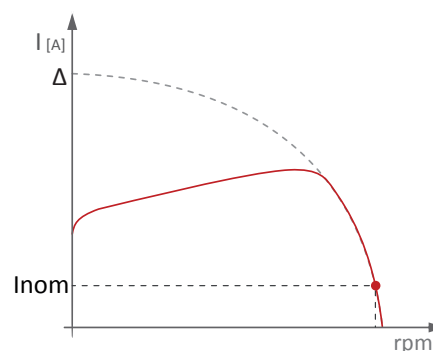

Current trend with accessory Electronic soft-starter

If the unit is equipped with the electronic soft-starter accessory, the starting of each compressor becomes of the DOL (Direct On Line) type and therefore with a higher effective average inrush current, but with an acceleration ramp that allows elimination of the peaks that would be generated when changing from star to delta. If the unit is equipped with accessory "Power factor correction to $\cos\phi \geq 0.95$ ", this last will be electro-mechanically connected only at the end of the acceleration ramp of the soft-starter.

SQE **Heater for electrical control panel**

Electric heaters are positioned inside the electrical control panel and these prevent the formation of ice or condensation inside it.

TERM **Remote-controlled user terminal panel**

This accessory allows the terminal normally situated on the machine to be replicated on a support situated at a distance. It is particularly suitable when the unit is placed in an area that is not easily accessible.

The accessory is supplied loose and is to be installed by the customer at a maximum distance of 120m from the unit. We advise using a cable of the following type: "TECO O.R. FE 2x2xAWG24 SN/ST/PUR".

For this accessory, there is a dedicated serial port.

Network accessories

BEET Blueeye® via Ethernet

Blueeye® is a supervision platform that enables remote monitoring of one or more units in the same system interconnected through a network with Modbus protocol.

This accessory features the Blueeye device, as already installed and wired in the unit.

The critical variables to be monitored over time are identified for each connected device. These variables are sampled and saved to the cloud so that they are accessible at all times through a web portal or a mobile APP (available for Android and iOS).

The following options can be selected for connection to the internet:

- a LAN (Ethernet) connection - available in the system;
- a connection to a mobile network - at least 3G. The data SIM card is not included.

Three different types of contracts can be signed.

Blueeye® Cloud Basic:

- to monitor a max. of 20 variables in total over max. 5 units/peripherals;
- to set a min. sampling frequency of 60 seconds.

Blueeye® Cloud Advanced:

- to monitor a max. of 200 variables in total over max. 10 units/peripherals;
- to set a min. sampling frequency of 5 seconds.

Blueeye® Connect:

- To monitor up to 10 units/peripherals.

Subscribing to any of the **Blueeye® Cloud** enables:

- viewing the history of the monitored variables, in the form of both numerical values and graphs;
- downloading the history of variables in CSV format;
- the creation of automatic reports;
- setting notifications (via APP or mail) with settable thresholds for each variable;
- switching the unit ON/OFF remotely;;
- changing the set point remotely;
- selection of SUMMER/WINTER mode remotely (for reversible units only).

The subscription to the **Blueeye® Connect** service offers the advantages below:

- a safe connection (tunnelling) between the user and the remote unit through the Blueeye® portal;
- full access to the remote controller;
- real time monitoring;
- software upgrading.

Blueeye® via Ethernet is only available for units supplied with an advanced controller and does not include any type of service. This service must be purchased separately based on the number of units/devices to be connected and the number of variables to be monitored. In order to connect multiple units to **Blueeye® device, the network switch is required (this accessory is sold separately).**

Units can also be connected to the Blueeye device through the RS485 network featuring a Modbus RTU protocol (for this option, refer to BERS accessory).

For further details, refer to the specific Blueeye® documentation.

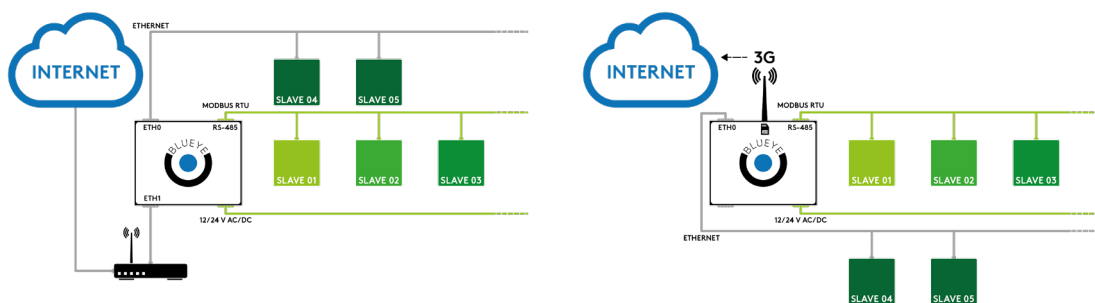

GLO Modbus Lonworks Gateway

With this accessory, a RS485/Lon gateway is installed inside the electrical control panel.

By default, the programming gives read-only access to the control of the unit. Enabling of read/write access should be requested when ordering.

FMx Multilogic Function

The Multilogic function allows management of up to 32 units equipped with advanced Bluethink controller and connected in hydraulic parallel with each other.

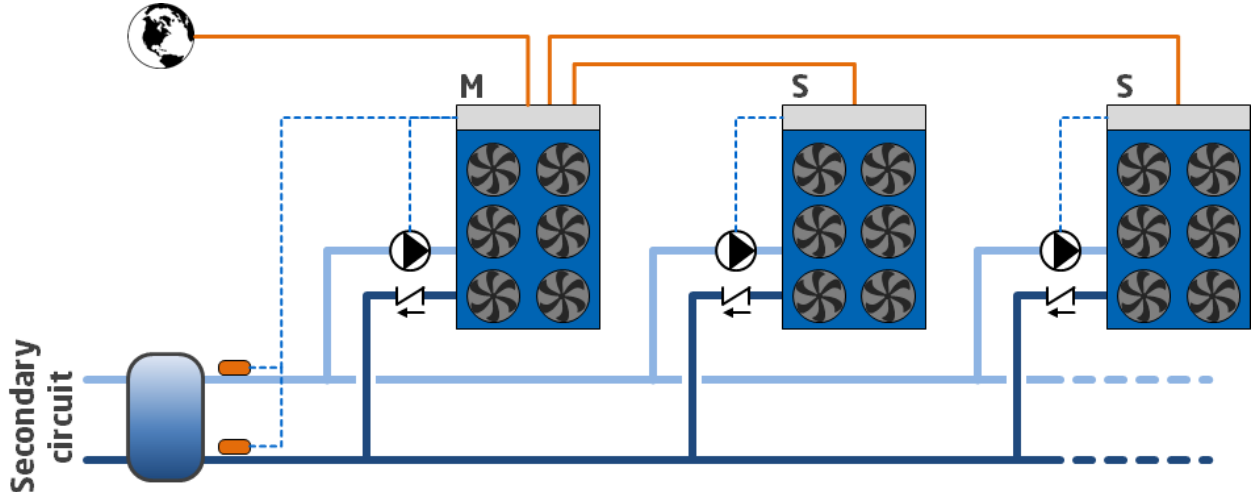

On the basis of the information recorded by the temperature probes installed on the delivery and return manifolds of the system, with the master unit, a capacity request is generated that is distributed among the units connected in the Multilogic network according to settable priority and optimization logics.

If communication between the units fails or if the master is off-line, the slave units can continue to work according to the set thermoregulation parameters.

The connected units can be different from each other, in terms of capacity and set-up, provided the following rules are complied with:

- if there are both chiller units and heat pumps in the Multilogic network, the Master unit must obligatorily be one of the HP units
- if there are both free cooling and non free-cooling units in the Multilogic network, the Master unit must obligatorily be one of the free-cooling units.

The Multilogic function that can be requested with the unit can be:

- **FM0:** Multilogic function for Slave unit
- **FM2:** Multilogic function for Master unit for managing up to 2 Slaves
- **FM6:** Multilogic function for Master unit for managing up to 6 Slaves

If you need to connect more than 6 slaves (up to 31), you can ask for a quotation from our sales department.

For the slave units, the accessory requires:

- programming of the unit as slave of a system of machines in Multilogic network

For the master units, the accessory requires:

- programming of the unit as master of a system of machines in Multilogic network
- entering of the parameters necessary for connection with the individual slave units
- installation in the electrical control panel of a network switch to allow the units to be connected in a LAN network.
- the supply of 2 temperature probes to be positioned on the delivery and return manifold of the system (supplied separately with it, installation and wiring by the customer)

The connection between the master unit and the slave units made with a CAT cable. 5E/UTP (prepared by the customer) with RJ45 connectors. Maximum cable length 100m.

For further details, please refer to the controller manual.

PBA BACnet protocol over IP (Ethernet)

The controller is set for use, in read and write mode, of the BACnet port on IP protocol.

By default, the programming gives read-only access to the control of the unit. Enabling of read/write access should be requested when ordering.

PSN SNMP protocol

The accessory consists of a gateway that allows Ethernet connection to a SNMP manager supervision system. The use of this accessory causes the RS485 serial port to be unavailable.

SERI RS485 serial connection with Modbus protocol

RS485 serial connection with Modbus protocol

SMAR Smartlink function predisposition

This accessory makes it possible to connect the controller of the unit with the controller of a Swegon GOLD™ air handling unit via a simple serial cable, so allowing their operating logics to be merged into a single consciousness that pursues the maximum energy efficiency of the system. The RS485 serial interface is already included and dedicated to connection with Swegon units.

The option is incompatible with:

- double set point
- variable set point with remote signal
- summer/winter selection by digital input
- set point compensation depending on external air temperature
- multilogic
- all communication protocols.

SW4P Network switch with 4 ports

The accessory includes installation in DIN rail of a professional 4-port network switch. Requires Blueye via Ethernet.

SW8P Network switch with 8 ports

The accessory includes installation in DIN rail of a professional 8-port network switch. Requires Blueye via Ethernet.

Other accessories

AG Rubber anti-vibration mounts

These allow you to reduce the vibrations transmitted from the unit to the surface it is standing on. Accessory supplied loose.

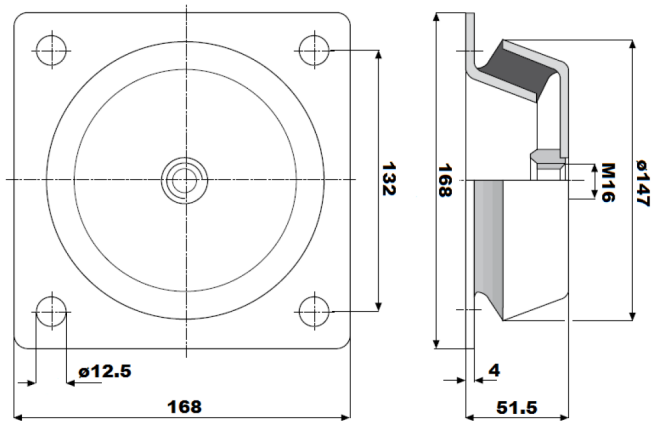

AM Spring anti-vibration mounts

These allow you to reduce the vibrations transmitted from the unit to the surface it is standing on. Accessory supplied loose.

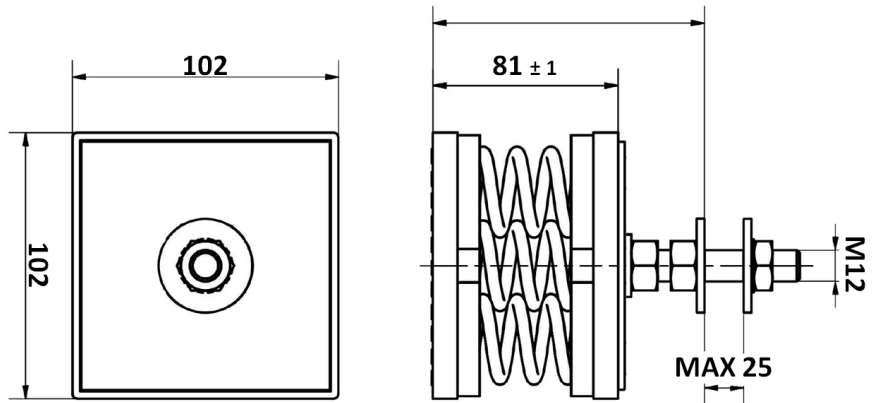

ALPR Pre-painted aluminium coil

This option uses finned pack coils with copper tubes and pre-painted aluminium fins.

ANTC Coil treated with anti-corrosion paints

The treatment is applied exclusively to finned pack coils with copper tubes and aluminium fins and consists of aluminium passivation and coating with a polyurethane base; a double layer of paint, of which the first passivates the aluminium and acts as primer and the second is a polyurethane based surface coating. The product has high resistance to corrosion and all environmental conditions.

The choice of whether or not to treat the exchanger should be made in relation to the environment in which the unit is to be installed and through observation of other structures and machinery with exposed metal surfaces present in the destination environment.

The cross observation criterion is the most valid method of selection currently available without having to carry out preliminary tests or measurements with instruments. The identified reference environments are:

- marine coastal
- industrial
- urban with a high housing density
- rural

MCHE E-coated microchannel coil

The e-coated microchannel coils are treated by immersion of the whole exchanger in an emulsion of organic resins, solvents, ionic stabilisers and deionised water. This is all subjected to a suitable electric field that causes the formation of a solid, uniform deposit on the exchanger. The function of this deposit will be to protect the aluminium from corrosion without penalising its thermophysical properties.

Protective treatment of the exchanger is strongly recommended if at least one of the points below is verified:

- there are obvious signs of corrosion of the exposed metal surfaces in the installation area
- the installation is located close to the sea coast
- the prevailing winds come from the sea towards the unit
- the environment is industrial with a significant concentration of pollutants
- the environment is urban with a high population density
- the environment is rural with the presence of organic discharges and effluents.

With reference to the protection criteria to follow, especially for installations close to the coast, refer to the section titled "Installations that require the use of treated coils".

PRAC Steel profiles frames for container shipment

This accessory foresees the mounting of steel profiles frames on the unit for its loading into container.

When this accessory is required it's for the shipping of the unit into container and its loading is mandatory to be done at the factory

PREA Unit suitable to be disassembled on site

The unit is delivered so that it can be disassembled easily on site if this makes the installation operations easier.

A unit requested with this option is supplied:

- screwed instead of riveted
- with plugged and not welded pipes
- without refrigerant charge
- untested
- covered by the warranty only if reassembled and screwed together by personnel authorized by the factory

RAAL Cu/Al coils

This accessory uses finned pack coils with copper tubes and aluminium fins instead of microchannel coils.

RAT Anti-intrusion nets

An arc-welded, painted net (RAL colour 7035) is installed to close off the external openings so as to prevent access to the technical compartment by unauthorized personnel.



SLCO Skid for shipping in container

The accessory provides for the installation of a wooden sled for loading and a fixing system inside the container by a strap. The accessory must be used for shipping in container. Loading on containers must be carried out at the factory. The accessory is incompatible with "Packaging in wooden crate".

STL Brackets for transport over long distances

The accessory consists of adding reinforcing bars to the structural metalwork. This allows the strength of the structure to be increased for long distance road transport.

TECHNICAL SPECIFICATIONS

KAPPA REV

			33.2	35.2	37.2	40.2	43.2	51.2	54.2	58.2
KAPPA REV										
Cooling (A35; W7)										
Refrigeration capacity	(1)	kW	308	340	372	409	459	483	538	612
Total absorbed power	(1)	kW	105	108	126	147	166	171	191	221
EER	(1)		2,91	3,14	2,95	2,79	2,75	2,81	2,81	2,76
KAPPA REV /HP										
Cooling (A35; W7)										
Refrigeration capacity	(1)	kW	296	328	358	393	440	464	518	587
Total absorbed power	(1)	kW	110	113	132	153	173	179	199	231
EER	(1)		2,69	2,90	2,72	2,57	2,53	2,59	2,60	2,54
Heating (A7/87%; W45)										
Heating capacity	(2)	kW	302	333	369	402	436	472	533	615
Total absorbed power	(2)	kW	97	105	117	130	141	151	172	198
COP	(2)		3,10	3,18	3,14	3,09	3,09	3,11	3,10	3,10
Compressors										
Compressors/Circuits	(8)	n°/n°	2/2	2/2	2/2	2/2	2/2	2/2	2/2	2/2
Minimum capacity reduction step		%	12%	12%	12%	11%	12%	12%	12%	12%
Refrigerant charge (CH + MCHX)		kg	39	44	44	46	43	48	52	63
Refrigerant charge (CH + CuAl)		kg	74	86	86	88	85	97	108	126
Refrigerant charge (HP)		kg	108	128	128	130	127	147	166	190
Fans										
Quantity		n°	5	6	6	6	6	7	8	9
Total air flow rate		m³/h	105.000	126.000	126.000	126.000	126.000	147.000	168.000	189.000
User-side heat exchanger										
Quantity		n°	1	1	1	1	1	1	1	1
Water flow rate (CH) (A35; W7)	(1)	m³/h	53,0	58,5	64,1	70,4	78,9	83,1	92,7	105,3
Head loss (CH) (A35; W7)	(1)	kPa	31	37	44	53	28	40	48	35
Water flow rate (HP) (A35; W7)	(1)	m³/h	51,0	56,5	61,7	67,7	75,6	79,8	89,1	101,0
Water flow rate (HP) (A7/87%; W45)	(2)	m³/h	51,9	57,2	63,3	69,0	74,8	81,1	91,6	105,6
Head loss (HP) (A35; W7)	(1)	kPa	29	35	41	50	26	30	36	32
Head loss (HP) (A7/87%; W45)	(2)	kPa	32	39	47	57	29	34	43	38
Noise levels										
Sound power level cooling	(3)	dB(A)	94	95	95	96	96	97	98	98
Sound power level heating	(6)	dB(A)	94	95	95	-	-	-	-	-
Sound pressure level cooling	(4)	dB(A)	62	63	63	64	64	65	66	66
Sound power level of vers. LN cooling	(3)	dB(A)	89	90	90	91	91	92	93	93
Sound power level of vers. LN heating	(6)	dB(A)	89	90	90	-	-	-	-	-
Sound pressure level of vers. LN cooling	(4)	dB(A)	57	58	58	59	59	59	61	60
Dimensions and weights**										
Length		mm	3.870	3.870	3.870	3.870	3.870	5.020	5.020	6.165
Depth		mm	2.260	2.260	2.260	2.260	2.260	2.260	2.260	2.260
Height		mm	2.440	2.440	2.440	2.440	2.440	2.440	2.440	2.440
Operating weight CH (MCHX)	(5)	kg	3.040	3.060	3.070	3.390	3.700	4.140	4.150	5.090

(CH: chiller unit; HP: heat pump unit; MCHX: unit with microchannel coils; CuAl: unit with copper/aluminium tube/fin coils)

- (1) Outside air temperature 35°C; evaporator inlet-outlet water temperature 12/7°C. Values compliant with standard EN 14511
- (2) Outside air temperature 7°C DB, 6°C WB; condenser inlet/outlet water temperature 40/45°C. Values compliant with standard EN 14511
- (3) Unit operating at nominal operating capacity, without any accessories, with external air temperature of 35°C and user-side heat exchanger water inlet/outlet temperature of 12/7°C. Binding values. Values obtained from measures taken according to standard ISO 3744 and to the Eurovent certification programme where applicable.
- (4) Values obtained from the sound power level (conditions: note 2), related to a distance of 10 m from the unit in free field with directivity factor Q=2. Non-binding values.
- (6) unit operating at nominal operating capacity, with no accessories of any kind, with external air temperature of 7°C (6°C WB) and user-side heat exchanger water inlet/outlet temperature of 40/45°C. Values obtained from measurements carried out in accordance with standard ISO 3744.
- (8) Approximate value. The minimum capacity reached by the unit depends on the operating conditions. The value shown may not be suitable for calculating the minimum volume of water: to do this, consult the "Minimum water content in the system" section.

** Basic CH unit without included accessories

KAPPA REV

			67.2	73.2	80.2	85.2	90.2	95.2	100.2	105.2
KAPPA REV										
Cooling (A35; W7)										
Refrigeration capacity	(1)	kW	688	736	786	839	889	951	994	1046
Total absorbed power	(1)	kW	240	250	260	289	319	339	357	377
EER	(1)		2,86	2,94	3,02	2,90	2,78	2,80	2,78	2,77
KAPPA REV /HP										
Cooling (A35; W7)										
Refrigeration capacity	(1)	kW	661	707	757	806	855	915	956	1036
Total absorbed power	(1)	kW	250	260	271	301	332	353	371	397
EER	(1)		2,64	2,71	2,79	2,67	2,57	2,59	2,57	2,60
Heating (A7/87%; W45)										
Heating capacity	(2)	kW	668	722	776	811	870	935	1001	1067
Total absorbed power	(2)	kW	215	229	241	258	275	295	314	343
COP	(2)		3,11	3,16	3,21	3,14	3,15	3,17	3,18	3,10
Compressors										
Compressors/Circuits	(8)	n°/n°	2/2	2/2	2/2	2/2	2/2	2/2	2/2	2/2
Minimum capacity reduction step		%	12%	12%	12%	12%	12%	12%	12%	12%
Refrigerant charge (CH + MCHX)		kg	70	75	83	83	87	98	102	115
Refrigerant charge (CH + CuAl)		kg	140	152	167	167	171	189	200	220
Refrigerant charge (HP)		kg	211	230	253	253	255	279	298	-
Fans										
Quantity		n°	10	11	12	12	12	13	14	15
Total air flow rate		m³/h	210.000	231.000	252.000	252.000	252.000	273.000	294.000	315.000
User-side heat exchanger										
Quantity		n°	1	1	1	1	1	1	1	1
Water flow rate (CH) (A35; W7)	(1)	m³/h	118,5	126,6	135,3	144,4	153,0	163,7	171,1	180,0
Head loss (CH) (A35; W7)	(1)	kPa	42	47	32	36	42	49	54	49
Water flow rate (HP) (A35; W7)	(1)	m³/h	113,8	121,7	130,3	138,7	147,1	157,4	164,5	178,3
Water flow rate (HP) (A7/87%; W45)	(2)	m³/h	114,8	124,1	133,3	139,3	149,5	160,7	171,9	183,3
Head loss (HP) (A35; W7)	(1)	kPa	39	44	30	33	39	46	51	36
Head loss (HP) (A7/87%; W45)	(2)	kPa	44	50	34	37	44	52	59	43
Noise levels										
Sound power level cooling	(3)	dB(A)	99	100	100	100	100	101	101	102
Sound power level heating	(6)	dB(A)	-	-	-	-	-	-	-	-
Sound pressure level cooling	(4)	dB(A)	67	67	67	68	68	68	68	69
Sound power level of vers. LN cooling	(3)	dB(A)	94	95	95	95	95	96	96	97
Sound power level of vers. LN heating	(6)	dB(A)	-	-	-	-	-	-	-	-
Sound pressure level of vers. LN cooling	(4)	dB(A)	62	63	63	63	62	63	63	64
Dimensions and weights**										
Length		mm	6.165	7.310	7.310	7.310	7.310	8.465	8.465	9.610
Depth		mm	2.260	2.260	2.260	2.260	2.260	2.260	2.260	2.260
Height		mm	2.440	2.440	2.440	2.440	2.440	2.440	2.440	2.440
Operating weight CH (MCHX)	(5)	kg	5.520	6.070	6.430	6.480	6.560	6.900	6.940	7.490

(CH: chiller unit; HP: heat pump unit; MCHX: unit with microchannel coils; CuAl: unit with copper/aluminium tube/fin coils)

- (1) Outside air temperature 35°C; evaporator inlet-outlet water temperature 12/7°C. Values compliant with standard EN 14511
- (2) Outside air temperature 7°C DB, 6°C WB; condenser inlet/outlet water temperature 40/45°C. Values compliant with standard EN 14511
- (3) Unit operating at nominal operating capacity, without any accessories, with external air temperature of 35°C and user-side heat exchanger water inlet/outlet temperature of 12/7°C. Binding values. Values obtained from measures taken according to standard ISO 3744 and to the Eurovent certification programme where applicable.
- (4) Values obtained from the sound power level (conditions: note 2), related to a distance of 10 m from the unit in free field with directivity factor Q=2. Non-binding values.
- (6) unit operating at nominal operating capacity, with no accessories of any kind, with external air temperature of 7°C (6°C WB) and user-side heat exchanger water inlet/outlet temperature of 40/45°C. Values obtained from measurements carried out in accordance with standard ISO 3744.
- (8) Approximate value. The minimum capacity reached by the unit depends on the operating conditions. The value shown may not be suitable for calculating the minimum volume of water: to do this, consult the "Minimum water content in the system" section.

** Basic CH unit without included accessories

KAPPA REV

			115.2	120.2	130.2	140.3	150.3	160.3	108.4	116.4
KAPPA REV										
Cooling (A35; W7)										
Refrigeration capacity	(1)	kW	1115	1203	1290	1441	1499	1545	1679	1778
Total absorbed power	(1)	kW	397	422	446	517	537	555	578	638
EER	(1)		2,80	2,85	2,89	2,78	2,79	2,78	2,90	2,78
KAPPA REV /HP										
Cooling (A35; W7)										
Refrigeration capacity	(1)	kW	1175	1323	1415	1515	1613	1710	1830	1913
Total absorbed power	(1)	kW	461	500	520	541	602	663	705	741
EER	(1)		2,54	2,64	2,72	2,79	2,67	2,58	2,59	2,57
Heating (A7/87%; W45)										
Heating capacity	(2)	kW	1229	1336	1444	1551	1622	1740	1870	2001
Total absorbed power	(2)	kW	396	429	457	482	515	550	589	627
COP	(2)		3,10	3,11	3,16	3,21	3,14	3,16	3,17	3,19
Compressors										
Compressors/Circuits	(8)	n°/n°	2/2	2/2	2/2	3/3	3/3	3/3	4/4	4/4
Minimum capacity reduction step		%	12%	12%	12%	8%	8%	8%	6%	6%
Refrigerant charge (CH + MCHX)		kg	122	132	136	149	160	165	-	-
Refrigerant charge (CH + CuAl)		kg	234	258	262	289	307	319	-	-
Refrigerant charge (HP)		kg	-	-	-	-	-	-	332	380
Fans										
Quantity		n°	16	18	18	20	21	22	16	18
Total air flow rate		m³/h	336.000	378.000	378.000	420.000	441.000	462.000	336.000	378.000
User-side heat exchanger										
Quantity		n°	1	1	1	1	1	1	2	2
Water flow rate (CH) (A35; W7)	(1)	m³/h	191,8	206,9	222,0	247,9	257,9	265,8	288,8	306,0
Head loss (CH) (A35; W7)	(1)	kPa	25	29	32	39	34	36	36	42
Water flow rate (HP) (A35; W7)	(1)	m³/h	202,1	227,6	243,4	260,6	277,5	294,3	314,8	329,1
Water flow rate (HP) (A7/87%; W45)	(2)	m³/h	211,2	229,7	248,2	266,6	278,7	299,0	321,5	343,9
Head loss (HP) (A35; W7)	(1)	kPa	32	39	44	30	33	39	46	51
Head loss (HP) (A7/87%; W45)	(2)	kPa	38	44	50	34	37	44	52	59
Noise levels										
Sound power level cooling	(3)	dB(A)	102	102	103	104	105	106	101	101
Sound power level heating	(6)	dB(A)	-	-	-	-	-	-	-	-
Sound pressure level cooling	(4)	dB(A)	69	69	70	71	71	72	69	69
Sound power level of vers. LN cooling	(3)	dB(A)	97	97	98	99	100	101	96	96
Sound power level of vers. LN heating	(6)	dB(A)	-	-	-	-	-	-	-	-
Sound pressure level of vers. LN cooling	(4)	dB(A)	64	64	65	66	67	68	64	63
Dimensions and weights**										
Length		mm	9.610	10.755	10.755	11.965	13.110	13.110	2 x 5.020	2 x 6.165
Depth		mm	2.260	2.260	2.260	2.260	2.260	2.260	2.260	2.260
Height		mm	2.440	2.440	2.440	2.440	2.440	2.440	2.440	2.440
Operating weight CH (MCHX)	(5)	kg	8.010	8.420	8.560				2 x 4.150	2 x 5.090

(CH: chiller unit; HP: heat pump unit; MCHX: unit with microchannel coils; CuAl: unit with copper/aluminium tube/fin coils)

- (1) Outside air temperature 35°C; evaporator inlet-outlet water temperature 12/7°C. Values compliant with standard EN 14511
- (2) Outside air temperature 7°C DB, 6°C WB; condenser inlet/outlet water temperature 40/45°C. Values compliant with standard EN 14511
- (3) Unit operating at nominal operating capacity, without any accessories, with external air temperature of 35°C and user-side heat exchanger water inlet/outlet temperature of 12/7°C. Binding values. Values obtained from measures taken according to standard ISO 3744 and to the Eurovent certification programme where applicable.
- (4) Values obtained from the sound power level (conditions: note 2), related to a distance of 10 m from the unit in free field with directivity factor Q=2. Non-binding values.
- (6) unit operating at nominal operating capacity, with no accessories of any kind, with external air temperature of 7°C (6°C WB) and user-side heat exchanger water inlet/outlet temperature of 40/45°C. Values obtained from measurements carried out in accordance with standard ISO 3744.
- (8) Approximate value. The minimum capacity reached by the unit depends on the operating conditions. The value shown may not be suitable for calculating the minimum volume of water: to do this, consult the "Minimum water content in the system" section.

** Basic CH unit without included accessories

KAPPA REV

			134.4	146.4	160.4	170.4	180.4	190.4	200.4
KAPPA REV									
Cooling (A35; W7)									
Refrigeration capacity	(1)	kW	1903	1989	-	1.675	1.774	1.898	1.983
Total absorbed power	(1)	kW	678	713	-	590	650	691	727
EER	(1)		2,80	2,78	-	2,84	2,73	2,75	2,73
KAPPA REV /HP									
Cooling (A35; W7)									
Refrigeration capacity	(1)	kW	1.320	1.412	1.512	1.610	1.707	1.825	1.907
Total absorbed power	(1)	kW	500	519	541	602	663	705	741
EER	(1)		2,64	2,72	2,79	2,67	2,57	2,59	2,57
Heating (A7/87%; W45)									
Heating capacity	(2)	kW	1.340	1.447	1.554	1.625	1.744	1.876	2.007
Total absorbed power	(2)	kW	430	455	482	515	550	589	627
COP	(2)		3,12	3,18	3,23	3,16	3,17	3,19	3,20
Compressors									
Compressors/Circuits	(8)	n°/n°	4/4	4/4	4/4	4/4	4/4	4/4	4/4
Minimum capacity reduction step		%	6%	6%	6%	6%	6%	6%	6%
Refrigerant charge (CH + MCHX)		kg	-	-	-	167	174	195	205
Refrigerant charge (CH + CuAl)		kg	-	-	-	335	342	377	401
Refrigerant charge (HP)		kg	422	461	505	505	510	558	596
Fans									
Quantity		n°	20	22	24	24	24	26	28
Total air flow rate		m³/h	420.000	462.000	504.000	504.000	504.000	546.000	588.000
User-side heat exchanger									
Quantity		n°	2	2	2	2	2	2	2
Water flow rate (CH) (A35; W7)	(1)	m³/h	327,4	342,2	-	293,7	311,1	332,9	347,9
Head loss (CH) (A35; W7)	(1)	kPa	49	54	-	36	42	50	55
Water flow rate (HP) (A35; W7)	(1)	m³/h	227,7	243,4	260,7	277,6	294,3	314,9	329,2
Water flow rate (HP) (A7/87%; W45)	(2)	m³/h	229,7	248,2	266,7	278,8	299,1	321,5	344,0
Head loss (HP) (A35; W7)	(1)	kPa	40	45	30	34	39	46	51
Head loss (HP) (A7/87%; W45)	(2)	kPa	44	51	35	37	45	53	60
Noise levels									
Sound power level cooling	(3)	dB(A)	102	103	103	103	103	104	104
Sound power level heating	(6)	dB(A)	-	-	-	-	-	-	-
Sound pressure level cooling	(4)	dB(A)	70	70	70	71	71	71	71
Sound power level of vers. LN cooling	(3)	dB(A)	97	98	98	98	98	99	99
Sound power level of vers. LN heating	(6)	dB(A)	-	-	-	-	-	-	-
Sound pressure level of vers. LN cooling	(4)	dB(A)	65	66	66	66	65	66	66
Dimensions and weights**									
Length		mm	2 x 6.165	2 x 7.310	2 x 7.310	2 x 7.310	2 x 7.310	2 x 8.465	2 x 8.465
Depth		mm	2.260	2.260	2.260	2.260	2.260	2.260	2.260
Height		mm	2.440	2.440	2.440	2.440	2.440	2.440	2.440
Operating weight CH (MCHX)	(5)	kg	2 x 5.520	2 x 6.070	2 x 6.430	2 x 6.480	2 x 6.560	2 x 6.900	2 x 6.940

(CH: chiller unit; HP: heat pump unit; MCHX: unit with microchannel coils; CuAl: unit with copper/aluminium tube/fin coils)

- (1) Outside air temperature 35°C; evaporator inlet-outlet water temperature 12/7°C. Values compliant with standard EN 14511
- (2) Outside air temperature 7°C DB, 6°C WB; condenser inlet/outlet water temperature 40/45°C. Values compliant with standard EN 14511
- (3) Unit operating at nominal operating capacity, without any accessories, with external air temperature of 35°C and user-side heat exchanger water inlet/outlet temperature of 12/7°C. Binding values. Values obtained from measures taken according to standard ISO 3744 and to the Eurovent certification programme where applicable.
- (4) Values obtained from the sound power level (conditions: note 2), related to a distance of 10 m from the unit in free field with directivity factor Q=2. Non-binding values.
- (6) unit operating at nominal operating capacity, with no accessories of any kind, with external air temperature of 7°C (6°C WB) and user-side heat exchanger water inlet/outlet temperature of 40/45°C. Values obtained from measurements carried out in accordance with standard ISO 3744.
- (8) Approximate value. The minimum capacity reached by the unit depends on the operating conditions. The value shown may not be suitable for calculating the minimum volume of water: to do this, consult the "Minimum water content in the system" section.

** Basic CH unit without included accessories

KAPPA REV HE

			33.2	35.2	37.2	40.2	43.2	51.2	54.2	58.2	67.2
KAPPA REV HE											
Cooling (A35; W7)											
Refrigeration capacity	(1)	kW	328	367	387	441	492	517	573	673	731
Total absorbed power	(1)	kW	102	114	120	138	154	161	178	210	230
EER	(1)		3,21	3,20	3,23	3,20	3,19	3,20	3,22	3,21	3,18
KAPPA REV HE /HP											
Cooling (A35; W7)											
Refrigeration capacity	(1)	kW	317	355	375	426	474	500	555	649	706
Total absorbed power	(1)	kW	107	120	126	144	161	169	186	220	240
EER	(1)		2,96	2,95	2,97	2,95	2,95	2,96	2,98	2,95	2,94
Heating (A7/87%; W45)											
Heating capacity	(2)	kW	318	367	397	434	471	504	579	662	704
Total absorbed power	(2)	kW	101	114	123	135	147	158	180	207	221
COP	(2)		3,15	3,21	3,21	3,20	3,19	3,19	3,21	3,19	3,18
Compressors											
Compressors/Circuits		n°/n°	2/2	2/2	2/2	2/2	2/2	2/2	2/2	2/2	2/2
Minimum capacity reduction step	(8)	%	12%	12%	12%	11%	12%	12%	12%	12%	12%
Refrigerant charge (CH + MCHX)		kg	46	52	52	56	56	68	77	83	83
Refrigerant charge (CH + CuAl)		kg	88	101	108	112	112	131	154	167	167
Refrigerant charge (HP)		kg	130	147	166	169	169	190	229	253	253
Fans											
Quantity		n°	6	7	8	8	8	9	11	12	12
Total air flow rate		m³/h	126.000	147.000	168.000	168.000	168.000	189.000	231.000	252.000	252.000
User-side heat exchanger											
Quantity		n°	1	1	1	1	1	1	1	1	1
Water flow rate (CH) (A35; W7)	(1)	m³/h	56,5	63,1	66,6	76,0	84,6	89,0	98,6	115,8	125,8
Head loss (CH) (A35; W7)	(1)	kPa	36	20	23	35	41	26	32	25	28
Water flow rate (HP) (A35; W7)	(1)	m³/h	54,5	61,0	64,5	73,4	81,6	86,0	95,4	111,7	121,4
Water flow rate (HP) (A7/87%; W45)	(2)	m³/h	54,6	63,0	68,1	74,5	80,9	86,6	99,4	113,7	121,0
Head loss (HP) (A35; W7)	(1)	kPa	34	19	27	33	21	24	17	23	26
Head loss (HP) (A7/87%; W45)	(2)	kPa	36	21	30	35	23	26	20	25	28
Noise levels											
Sound power level cooling	(3)	dB(A)	94	95	95	96	96	97	98	98	99
Sound power level heating	(6)	dB(A)	94	95	95	-	-	-	-	-	-
Sound pressure level cooling	(4)	dB(A)	62	62	62	63	63	65	66	66	67
Sound power level of vers. LN cooling	(3)	dB(A)	89	90	90	91	91	92	93	93	94
Sound power level of vers. LN heating	(6)	dB(A)	89	90	90	-	-	-	-	-	-
Sound pressure level of vers. LN cooling	(4)	dB(A)	57	58	58	59	59	59	61	60	62
Dimensions and weights**											
Length		mm	3.870	5.020	5.020	5.020	5.020	6.165	7.310	7.310	7.310
Depth		mm	2.260	2.260	2.260	2.260	2.260	2.260	2.260	2.260	2.260
Height		mm	2.440	2.440	2.440	2.440	2.440	2.440	2.440	2.440	2.440
Operating weight CH (MCHX)	(5)	kg	3.070	3.500	3.510	3.830	4.140	4.660	5.210	6.000	6.410

(CH: chiller unit; HP: heat pump unit; MCHX: unit with microchannel coils; CuAl: unit with copper/aluminium tube/fin coils)

- (1) Outside air temperature 35°C; evaporator inlet-outlet water temperature 12/7°C. Values compliant with standard EN 14511
- (2) Outside air temperature 7°C DB, 6°C WB; condenser inlet/outlet water temperature 40/45°C. Values compliant with standard EN 14511
- (3) Unit operating at nominal operating capacity, without any accessories, with external air temperature of 35°C and user-side heat exchanger water inlet/outlet temperature of 12/7°C. Binding values. Values obtained from measures taken according to standard ISO 3744 and to the Eurovent certification programme where applicable.
- (4) Values obtained from the sound power level (conditions: note 2), related to a distance of 10 m from the unit in free field with directivity factor Q=2. Non-binding values.
- (6) unit operating at nominal operating capacity, with no accessories of any kind, with external air temperature of 7°C (6°C WB) and user-side heat exchanger water inlet/outlet temperature of 40/45°C. Values obtained from measurements carried out in accordance with standard ISO 3744.
- (8) Approximate value. The minimum capacity reached by the unit depends on the operating conditions. The value shown may not be suitable for calculating the minimum volume of water: to do this, consult the "Minimum water content in the system" section.

** Basic CH unit without included accessories

KAPPA REV HE

			73.2	80.2	85.2	90.2	95.2	100.2	105.2	115.2	120.2
KAPPA REV HE											
Cooling (A35; W7)											
Refrigeration capacity	(1)	kW	769	813	885	952	1023	1085	1139	1207	1300
Total absorbed power	(1)	kW	241	254	276	298	320	339	357	378	407
EER	(1)		3,19	3,20	3,20	3,19	3,19	3,20	3,19	3,19	3,19
KAPPA REV HE /HP											
Cooling (A35; W7)											
Refrigeration capacity	(1)	kW	742	786	853	949	1000	1109	1299	1412	1484
Total absorbed power	(1)	kW	252	265	288	321	337	372	439	479	504
EER	(1)		2,94	2,97	2,96	2,95	2,96	2,98	2,95	2,94	2,94
Heating (A7/87%; W45)											
Heating capacity	(2)	kW	758	812	867	941	1009	1157	1323	1408	1516
Total absorbed power	(2)	kW	235	249	271	294	315	360	414	442	470
COP	(2)		3,22	3,26	3,20	3,19	3,20	3,21	3,19	3,18	3,22
Compressors											
Compressors/Circuits		n°/n°	2/2	2/2	2/2	2/2	2/2	2/2	2/2	2/2	2/2
Minimum capacity reduction step	(8)	%	12%	12%	12%	12%	12%	12%	12%	12%	12%
Refrigerant charge (CH + MCHX)		kg	92	92	105	111	128	128	141	145	154
Refrigerant charge (CH + CuAl)		kg	183	190	210	223	247	254	274	292	308
Refrigerant charge (HP)		kg	272	291	-	-	-	-	-	-	-
Fans											
Quantity		n°	13	14	15	16	17	18	19	21	22
Total air flow rate		m³/h	273.000	294.000	315.000	336.000	357.000	378.000	399.000	441.000	462.000
User-side heat exchanger											
Quantity		n°	1	1	1	1	1	1	1	1	1
Water flow rate (CH) (A35; W7)	(1)	m³/h	132,4	139,9	152,3	163,9	176,0	186,6	196,0	207,7	223,6
Head loss (CH) (A35; W7)	(1)	kPa	31	35	43	50	47	52	25	28	32
Water flow rate (HP) (A35; W7)	(1)	m³/h	127,6	135,3	146,8	163,3	172,0	190,8	223,5	242,9	255,3
Water flow rate (HP) (A7/87%; W45)	(2)	m³/h	130,2	139,5	149,0	161,8	173,4	198,9	227,4	242,0	260,5
Head loss (HP) (A35; W7)	(1)	kPa	29	35	33	21	24	17	23	26	29
Head loss (HP) (A7/87%; W45)	(2)	kPa	32	38	35	23	26	20	25	28	32
Noise levels											
Sound power level cooling	(3)	dB(A)	100	100	100	100	101	101	102	102	102
Sound power level heating	(6)	dB(A)	-	-	-	-	-	-	-	-	-
Sound pressure level cooling	(4)	dB(A)	67	67	67	67	68	68	69	69	69
Sound power level of vers. LN cooling	(3)	dB(A)	95	95	95	95	96	96	97	97	97
Sound power level of vers. LN heating	(6)	dB(A)	-	-	-	-	-	-	-	-	-
Sound pressure level of vers. LN cooling	(4)	dB(A)	62	62	62	62	63	63	64	64	64
Dimensions and weights**											
Length		mm	8.465	8.465	9.610	9.610	10.755	10.755	11.965	13.110	13.110
Depth		mm	2.260	2.260	2.260	2.260	2.260	2.260	2.260	2.260	2.260
Height		mm	2.440	2.440	2.440	2.440	2.440	2.440	2.440	2.440	2.440
Operating weight CH (MCHX)	(5)	kg	6.740	6.760	7.140	7.220	8.420	8.560	8.810	9.350	9.410

(CH: chiller unit; HP: heat pump unit; MCHX: unit with microchannel coils; CuAl: unit with copper/aluminium tube/fin coils)

- (1) Outside air temperature 35°C; evaporator inlet-outlet water temperature 12/7°C. Values compliant with standard EN 14511
- (2) Outside air temperature 7°C DB, 6°C WB; condenser inlet/outlet water temperature 40/45°C. Values compliant with standard EN 14511
- (3) Unit operating at nominal operating capacity, without any accessories, with external air temperature of 35°C and user-side heat exchanger water inlet/outlet temperature of 12/7°C. Binding values. Values obtained from measures taken according to standard ISO 3744 and to the Eurovent certification programme where applicable.
- (4) Values obtained from the sound power level (conditions: note 2), related to a distance of 10 m from the unit in free field with directivity factor Q=2. Non-binding values.
- (6) unit operating at nominal operating capacity, with no accessories of any kind, with external air temperature of 7°C (6°C WB) and user-side heat exchanger water inlet/outlet temperature of 40/45°C. Values obtained from measurements carried out in accordance with standard ISO 3744.
- (8) Approximate value. The minimum capacity reached by the unit depends on the operating conditions. The value shown may not be suitable for calculating the minimum volume of water: to do this, consult the "Minimum water content in the system" section.

** Basic CH unit without included accessories

KAPPA REV HE

			80.4	86.4	102.4	108.4	116.4	134.4	146.4	160.4
KAPPA REV HE										
Cooling (A35; W7)										
Refrigeration capacity	(1)	kW	1463	1539	1626	-	-	1.461	1.536	1.623
Total absorbed power	(1)	kW	459	482	507	-	-	471	495	521
EER	(1)		3,18	3,19	3,20	-	-	3,10	3,10	3,11
KAPPA REV HE /HP										
Cooling (A35; W7)										
Refrigeration capacity	(1)	kW	1573	948	998	1.108	1.297	1.410	1.482	1.570
Total absorbed power	(1)	kW	529	321	337	372	439	479	504	529
EER	(1)		2,97	2,95	2,96	2,98	2,95	2,94	2,94	2,97
Heating (A7/87%; W45)										
Heating capacity	(2)	kW	1623	942	1.010	1.158	1.325	1.410	1.518	1.627
Total absorbed power	(2)	kW	498	288	309	353	406	434	461	488
COP	(2)		3,26	3,27	3,27	3,28	3,27	3,25	3,30	3,33
Compressors										
Compressors/Circuits		n°/n°	4/4	4/4	4/4	4/4	4/4	4/4	4/4	4/4
Minimum capacity reduction step	(8)	%	6%	6%	6%	6%	6%	6%	6%	6%
Refrigerant charge (CH + MCHX)		kg	-	-	-	-	-	167	185	185
Refrigerant charge (CH + CuAl)		kg	-	-	-	-	-	335	367	381
Refrigerant charge (HP)		kg	337	337	380	457	505	505	544	583
Fans										
Quantity		n°	16	16	18	22	24	24	26	28
Total air flow rate		m³/h	336.000	336.000	378.000	462.000	504.000	504.000	546.000	588.000
User-side heat exchanger										
Quantity		n°	2	2	2	2	2	2	2	2
Water flow rate (CH) (A35; W7)	(1)	m³/h	251,7	264,8	279,8	-	-	251,8	264,9	279,8
Head loss (CH) (A35; W7)	(1)	kPa	28	31	35	-	-	28	32	36
Water flow rate (HP) (A35; W7)	(1)	m³/h	270,6	163,3	172,1	190,9	223,6	242,9	255,4	270,7
Water flow rate (HP) (A7/87%; W45)	(2)	m³/h	279,0	161,8	173,4	198,9	227,4	242,1	260,6	279,1
Head loss (HP) (A35; W7)	(1)	kPa	35	22	25	18	24	26	30	35
Head loss (HP) (A7/87%; W45)	(2)	kPa	38	24	27	20	26	29	33	39
Noise levels										
Sound power level cooling	(3)	dB(A)	99	99	100	101	101	102	103	103
Sound power level heating	(6)	dB(A)	-	-	-	-	-	-	-	-
Sound pressure level cooling	(4)	dB(A)	66	66	68	69	69	70	70	70
Sound power level of vers. LN cooling	(3)	dB(A)	94	94	95	96	96	97	98	98
Sound power level of vers. LN heating	(6)	dB(A)	-	-	-	-	-	-	-	-
Sound pressure level of vers. LN cooling	(4)	dB(A)	62	62	62	64	63	65	65	65
Dimensions and weights**										
Length		mm	2 x 5.020	2 x 5.020	2 x 6.165	2 x 7.310	2 x 7.310	2 x 7.310	2 x 8.465	2 x 8.465
Depth		mm	2.260	2.260	2.260	2.260	2.260	2.260	2.260	2.260
Height		mm	2.440	2.440	2.440	2.440	2.440	2.440	2.440	2.440
Operating weight CH (MCHX)	(5)	kg	2 x 3.830	2 x 4.140	2 x 4.660	2 x 5.210	2 x 6.000	2 x 6.410	2 x 6.740	2 x 6.760

(CH: chiller unit; HP: heat pump unit; MCHX: unit with microchannel coils; CuAl: unit with copper/aluminium tube/fin coils)

- (1) Outside air temperature 35°C; evaporator inlet-outlet water temperature 12/7°C. Values compliant with standard EN 14511
- (2) Outside air temperature 7°C DB, 6°C WB; condenser inlet/outlet water temperature 40/45°C. Values compliant with standard EN 14511
- (3) Unit operating at nominal operating capacity, without any accessories, with external air temperature of 35°C and user-side heat exchanger water inlet/outlet temperature of 12/7°C. Binding values. Values obtained from measures taken according to standard ISO 3744 and to the Eurovent certification programme where applicable.
- (4) Values obtained from the sound power level (conditions: note 2), related to a distance of 10 m from the unit in free field with directivity factor Q=2. Non-binding values.
- (6) unit operating at nominal operating capacity, with no accessories of any kind, with external air temperature of 7°C (6°C WB) and user-side heat exchanger water inlet/outlet temperature of 40/45°C. Values obtained from measurements carried out in accordance with standard ISO 3744.
- (8) Approximate value. The minimum capacity reached by the unit depends on the operating conditions. The value shown may not be suitable for calculating the minimum volume of water: to do this, consult the "Minimum water content in the system" section.

** Basic CH unit without included accessories

KAPPA REV SLN

			33.2	35.2	37.2	40.2	43.2	51.2	54.2	58.2	67.2
KAPPA REV SLN											
Cooling (A35; W7)											
Refrigeration capacity	(1)	kW	316	354	375	425	472	498	554	648	703
Total absorbed power	(1)	kW	104	117	121	141	159	166	182	215	236
EER	(1)		3,03	3,03	3,08	3,01	2,96	3,00	3,04	3,01	2,98
KAPPA REV SLN /HP											
Cooling (A35; W7)											
Refrigeration capacity	(1)	kW	317	355	375	426	474	500	555	649	706
Total absorbed power	(1)	kW	107	120	126	144	161	169	186	220	240
EER	(1)		2,96	2,95	2,97	2,95	2,95	2,96	2,98	2,95	2,94
Heating (A7/87%; W45)											
Heating capacity	(2)	kW	318	367	397	434	471	504	579	662	704
Total absorbed power	(2)	kW	101	114	123	135	147	158	180	207	221
COP	(2)		3,15	3,21	3,21	3,20	3,19	3,19	3,21	3,19	3,18
Compressors											
Compressors/Circuits		n°/n°	2/2	2/2	2/2	2/2	2/2	2/2	2/2	2/2	2/2
Minimum capacity reduction step	(8)	%	12%	12%	12%	11%	12%	12%	12%	12%	12%
Refrigerant charge (CH + MCHX)		kg	46	52	52	56	56	68	77	83	83
Refrigerant charge (CH + CuAl)		kg	88	101	108	112	112	131	154	167	167
Refrigerant charge (HP)		kg	130	147	166	169	169	190	229	253	253
Fans											
Quantity		n°	6	7	8	8	8	9	11	12	12
Total air flow rate		m³/h	96.000	112.000	128.000	128.000	128.000	144.000	176.000	192.000	192.000
User-side heat exchanger											
Quantity		n°	1	1	1	1	1	1	1	1	1
Water flow rate (CH) (A35; W7)	(1)	m³/h	54,4	60,9	64,5	73,1	81,2	85,7	95,3	111,5	120,9
Head loss (CH) (A35; W7)	(1)	kPa	34	19	22	33	38	24	30	23	26
Water flow rate (HP) (A35; W7)	(1)	m³/h	54,5	61,0	64,5	73,4	81,6	86,0	95,4	111,7	121,4
Water flow rate (HP) (A7/87%; W45)	(2)	m³/h	54,6	63,0	68,1	74,5	80,9	86,6	99,4	113,7	121,0
Head loss (HP) (A35; W7)	(1)	kPa	34	19	27	33	21	24	17	23	26
Head loss (HP) (A7/87%; W45)	(2)	kPa	36	21	30	35	23	26	20	25	28
Noise levels											
Sound power level cooling	(3)	dB(A)	86	87	87	88	88	89	90	90	91
Sound power level heating	(6)	dB(A)	94	95	95	-	-	-	-	-	-
Sound pressure level cooling	(4)	dB(A)	54	55	54	56	56	57	58	58	59
Dimensions and weights**											
Length		mm	3.870	5.020	5.020	5.020	5.020	6.165	7.310	7.310	7.310
Depth		mm	2.260	2.260	2.260	2.260	2.260	2.260	2.260	2.260	2.260
Height		mm	2.440	2.440	2.440	2.440	2.440	2.440	2.440	2.440	2.440
Operating weight CH (MCHX)	(5)	kg	3.460	3.960	3.970	4.290	4.600	5.160	5.730	6.520	6.930

(CH: chiller unit; HP: heat pump unit; MCHX: unit with microchannel coils; CuAl: unit with copper/aluminium tube/fin coils)

- (1) Outside air temperature 35°C; evaporator inlet-outlet water temperature 12/7°C. Values compliant with standard EN 14511
- (2) Outside air temperature 7°C DB, 6°C WB; condenser inlet/outlet water temperature 40/45°C. Values compliant with standard EN 14511
- (3) Unit operating at nominal operating capacity, without any accessories, with external air temperature of 35°C and user-side heat exchanger water inlet/outlet temperature of 12/7°C. Binding values. Values obtained from measures taken according to standard ISO 3744 and to the Eurovent certification programme where applicable.
- (4) Values obtained from the sound power level (conditions: note 2), related to a distance of 10 m from the unit in free field with directivity factor Q=2. Non-binding values.
- (6) unit operating at nominal operating capacity, with no accessories of any kind, with external air temperature of 7°C (6°C WB) and user-side heat exchanger water inlet/outlet temperature of 40/45°C. Values obtained from measurements carried out in accordance with standard ISO 3744.
- (8) Approximate value. The minimum capacity reached by the unit depends on the operating conditions. The value shown may not be suitable for calculating the minimum volume of water: to do this, consult the "Minimum water content in the system" section.

** Basic CH unit without included accessories

KAPPA REV SLN

			73.2	80.2	85.2	90.2	95.2	100.2	105.2	115.2	120.2
KAPPA REV SLN											
Cooling (A35; W7)											
Refrigeration capacity	(1)	kW	739	783	852	918	985	1044	1097	1166	1253
Total absorbed power	(1)	kW	247	259	283	306	329	348	366	385	417
EER	(1)		2,99	3,02	3,01	3,00	2,99	3,00	2,99	3,02	3,00
KAPPA REV SLN /HP											
Cooling (A35; W7)											
Refrigeration capacity	(1)	kW	742	786	853	949	1000	1109	1299	1412	1484
Total absorbed power	(1)	kW	252	265	288	321	337	372	439	479	504
EER	(1)		2,94	2,97	2,96	2,95	2,96	2,98	2,95	2,94	2,94
Heating (A7/87%; W45)											
Heating capacity	(2)	kW	758	812	867	941	1009	1157	1323	1408	1516
Total absorbed power	(2)	kW	235	249	271	294	315	360	414	442	470
COP	(2)		3,22	3,26	3,20	3,19	3,20	3,21	3,19	3,18	3,22
Compressors											
Compressors/Circuits		n°/n°	2/2	2/2	2/2	2/2	2/2	2/2	2/2	2/2	2/2
Minimum capacity reduction step	(8)	%	12%	12%	12%	12%	12%	12%	12%	12%	12%
Refrigerant charge (CH + MCHX)		kg	92	92	105	111	128	128	141	145	154
Refrigerant charge (CH + CuAl)		kg	183	190	210	223	247	254	274	292	308
Refrigerant charge (HP)		kg	272	291	-	-	-	-	-	-	-
Fans											
Quantity		n°	13	14	15	16	17	18	19	21	22
Total air flow rate		m³/h	208.000	224.000	240.000	256.000	272.000	288.000	304.000	336.000	352.000
User-side heat exchanger											
Quantity		n°	1	1	1	1	1	1	1	1	1
Water flow rate (CH) (A35; W7)	(1)	m³/h	127,2	134,7	146,7	158,0	169,5	179,7	188,7	200,6	215,6
Head loss (CH) (A35; W7)	(1)	kPa	29	33	40	47	44	49	23	26	30
Water flow rate (HP) (A35; W7)	(1)	m³/h	127,6	135,3	146,8	163,3	172,0	190,8	223,5	242,9	255,3
Water flow rate (HP) (A7/87%; W45)	(2)	m³/h	130,2	139,5	149,0	161,8	173,4	198,9	227,4	242,0	260,5
Head loss (HP) (A35; W7)	(1)	kPa	29	35	33	21	24	17	23	26	29
Head loss (HP) (A7/87%; W45)	(2)	kPa	32	38	35	23	26	20	25	28	32
Noise levels											
Sound power level cooling	(3)	dB(A)	92	92	92	92	93	93	94	94	94
Sound power level heating	(6)	dB(A)	-	-	-	-	-	-	-	-	-
Sound pressure level cooling	(4)	dB(A)	59	59	59	59	60	60	61	61	61
Dimensions and weights**											
Length		mm	8.465	8.465	9.610	9.610	10.755	10.755	11.965	13.110	13.110
Depth		mm	2.260	2.260	2.260	2.260	2.260	2.260	2.260	2.260	2.260
Height		mm	2.440	2.440	2.440	2.440	2.440	2.440	2.440	2.440	2.440
Operating weight CH (MCHX)	(5)	kg	7.260	7.280	7.700	7.770	8.350	8.410	9.370	9.900	9.970

(CH: chiller unit; HP: heat pump unit; MCHX: unit with microchannel coils; CuAl: unit with copper/aluminium tube/fin coils)

(1) Outside air temperature 35°C; evaporator inlet-outlet water temperature 12/7°C. Values compliant with standard EN 14511

(2) Outside air temperature 7°C DB, 6°C WB; condenser inlet/outlet water temperature 40/45°C. Values compliant with standard EN 14511

(3) Unit operating at nominal operating capacity, without any accessories, with external air temperature of 35°C and user-side heat exchanger water inlet/outlet temperature of 12/7°C. Binding values. Values obtained from measures taken according to standard ISO 3744 and to the Eurovent certification programme where applicable.

(4) Values obtained from the sound power level (conditions: note 2), related to a distance of 10 m from the unit in free field with directivity factor Q=2. Non-binding values.

(6) unit operating at nominal operating capacity, with no accessories of any kind, with external air temperature of 7°C (6°C WB) and user-side heat exchanger water inlet/outlet temperature of 40/45°C. Values obtained from measurements carried out in accordance with standard ISO 3744.

(8) Approximate value. The minimum capacity reached by the unit depends on the operating conditions. The value shown may not be suitable for calculating the minimum volume of water: to do this, consult the "Minimum water content in the system" section.

** Basic CH unit without included accessories

KAPPA REV SLN

			80.4	86.4	102.4	108.4	116.4	134.4	146.4	160.4
KAPPA REV SLN										
Cooling (A35; W7)										
Refrigeration capacity	(1)	kW	1406	1479	1566	-	-	1.404	1.477	1.563
Total absorbed power	(1)	kW	471	494	518	-	-	478	502	526
EER	(1)		2,98	2,99	3,02	-	-	2,94	2,94	2,97
KAPPA REV SLN /HP										
Cooling (A35; W7)										
Refrigeration capacity	(1)	kW	1573	911	962	1.072	1.253	1.357	1.427	1.514
Total absorbed power	(1)	kW	529	326	340	373	441	483	507	530
EER	(1)		2,97	2,79	2,83	2,88	2,84	2,81	2,82	2,86
Heating (A7/87%; W45)										
Heating capacity	(2)	kW	1623	942	1.010	1.158	1.325	1.410	1.518	1.627
Total absorbed power	(2)	kW	498	288	309	353	406	434	461	488
COP	(2)		3,26	3,27	3,27	3,28	3,27	3,25	3,30	3,33
Compressors										
Compressors/Circuits		n°/n°	4/4	4/4	4/4	4/4	4/4	4/4	4/4	4/4
Minimum capacity reduction step	(8)	%	6%	6%	6%	6%	6%	6%	6%	6%
Refrigerant charge (CH + MCHX)		kg	-	-	-	-	-	167	185	185
Refrigerant charge (CH + CuAl)		kg						335	367	381
Refrigerant charge (HP)		kg	337	337	380	457	505	505	544	583
Fans										
Quantity		n°	16	16	18	22	24	24	26	28
Total air flow rate		m³/h	256.000	256.000	288.000	352.000	384.000	384.000	416.000	448.000
User-side heat exchanger										
Quantity		n°	2	2	2	2	2	2	2	2
Water flow rate (CH) (A35; W7)	(1)	m³/h	241,9	254,5	269,4	-	-	241,9	254,5	269,5
Head loss (CH) (A35; W7)	(1)	kPa	26	29	33	-	-	26	30	33
Water flow rate (HP) (A35; W7)	(1)	m³/h	270,6	157,0	165,8	184,8	215,9	233,8	246,0	261,0
Water flow rate (HP) (A7/87%; W45)	(2)	m³/h	279,0	161,8	173,4	198,9	227,4	242,1	260,6	279,1
Head loss (HP) (A35; W7)	(1)	kPa	35	36	23	29	22	25	28	31
Head loss (HP) (A7/87%; W45)	(2)	kPa	38	24	27	20	26	29	33	39
Noise levels										
Sound power level cooling	(3)	dB(A)	91	91	92	93	93	94	95	95
Sound power level heating	(6)	dB(A)	-	-	-	-	-	-	-	-
Sound pressure level cooling	(4)	dB(A)	59	59	60	61	61	62	62	62
Dimensions and weights**										
Length		mm	2 x 5.020	2 x 5.020	2 x 6.165	2 x 7.310	2 x 7.310	2 x 7.310	2 x 8.465	2 x 8.465
Depth		mm	2.260	2.260	2.260	2.260	2.260	2.260	2.260	2.260
Height		mm	2.440	2.440	2.440	2.440	2.440	2.440	2.440	2.440
Operating weight CH (MCHX)	(5)	kg	2 x 4.290	2 x 4.600	2 x 5.160	2 x 5.730	2 x 6.520	2 x 6.930	2 x 7.260	2 x 7.280

(CH: chiller unit; HP: heat pump unit; MCHX: unit with microchannel coils; CuAl: unit with copper/aluminium tube/fin coils)

- (1) Outside air temperature 35°C; evaporator inlet-outlet water temperature 12/7°C. Values compliant with standard EN 14511
- (2) Outside air temperature 7°C DB, 6°C WB; condenser inlet/outlet water temperature 40/45°C. Values compliant with standard EN 14511
- (3) Unit operating at nominal operating capacity, without any accessories, with external air temperature of 35°C and user-side heat exchanger water inlet/outlet temperature of 12/7°C. Binding values. Values obtained from measures taken according to standard ISO 3744 and to the Eurovent certification programme where applicable.
- (4) Values obtained from the sound power level (conditions: note 2), related to a distance of 10 m from the unit in free field with directivity factor Q=2. Non-binding values.
- (6) unit operating at nominal operating capacity, with no accessories of any kind, with external air temperature of 7°C (6°C WB) and user-side heat exchanger water inlet/outlet temperature of 40/45°C. Values obtained from measurements carried out in accordance with standard ISO 3744.
- (8) Approximate value. The minimum capacity reached by the unit depends on the operating conditions. The value shown may not be suitable for calculating the minimum volume of water: to do this, consult the "Minimum water content in the system" section.

** Basic CH unit without included accessories

KAPPA REV (R513A)

			33.2	35.2	37.2	40.2	43.2	51.2
KAPPA REV (R513A)								
Cooling (A35; W7)								
Refrigeration capacity	(1)	kW	312	351	373	410	453	489
Total absorbed power	(1)	kW	111	111	133	154	172	183
EER	(1)		2,80	3,16	2,80	2,65	2,63	2,67
Compressors								
Compressors/Circuits	(8)	n°/n°	2/2	2/2	2/2	2/2	2/2	2/2
Minimum capacity reduction step		%	12%	13%	13%	11%	13%	12%
Refrigerant charge (CH + MCHX)		kg	39	44	44	46	43	48
Refrigerant charge (CH + CuAl)		kg	74	86	86	88	85	97
Fans								
Quantity		n°	5	6	6	6	6	7
Total air flow rate		m³/h	105000	126000	126000	126000	126000	147000
User-side heat exchanger								
Quantity		n°	1	1	1	1	1	1
Water flow rate (CH) (A35; W7)	(1)	m³/h	53,6	60,3	64,2	70,5	77,9	84,1
Head loss (CH) (A35; W7)	(1)	kPa	31	37	44	53	28	40
Noise levels								
Sound power level cooling	(3)	dB(A)	94	95	95	96	96	97
Sound pressure level cooling	(4)	dB(A)	62	63	63	64	64	65
Sound power level of vers. LN cooling	(3)	dB(A)	89	90	90	91	91	92
Sound pressure level of vers. LN cooling	(4)	dB(A)	57	58	58	59	59	59
Dimensions and weights**								
Length		mm	3.870	3.870	3.870	3.870	3.870	5.020
Depth		mm	2.260	2.260	2.260	2.260	2.260	2.260
Height		mm	2.440	2.440	2.440	2.440	2.440	2.440
Operating weight CH (MCHX)	(5)	kg	3.040	3.060	3.070	3.390	3.700	4.140

(CH: chiller unit; HP: heat pump unit; MCHX: unit with microchannel coils; CuAl: unit with copper/aluminium tube/fin coils)

(1) Outside air temperature 35°C; evaporator inlet-outlet water temperature 12/7°C. Values compliant with standard EN 14511

(2) Outside air temperature 7°C DB, 6°C WB; condenser inlet/outlet water temperature 40/45°C. Values compliant with standard EN 14511

(3) Unit operating at nominal operating capacity, without any accessories, with external air temperature of 35°C and user-side heat exchanger water inlet/outlet temperature of 12/7°C. Binding values. Values obtained from measures taken according to standard ISO 3744 and to the Eurovent certification programme where applicable.

(4) Values obtained from the sound power level (conditions: note 2), related to a distance of 10 m from the unit in free field with directivity factor Q=2. Non-binding values.

(5) The weight refers to the unit without any accessory. The introduction of a few accessories such as copper/aluminum coils, hydraulic modules or the recovery exchangers can lead to weight increased that can exceed 10%. For further details refer to the specific drawing of the selected configuration.

(8) Approximate value. The minimum capacity reached by the unit depends on the operating conditions. The value shown may not be suitable for calculating the minimum volume of water: to do this, consult the "Minimum water content in the system" section.

** Basic CH unit without included accessories

KAPPA REV (R513A)

			54.2	58.2	67.2	73.2	80.2	85.2
KAPPA REV (R513A)								
Cooling (A35; W7)								
Refrigeration capacity	(1)	kW	564	606	682	736	775	826
Total absorbed power	(1)	kW	207	231	250	263	270	300
EER	(1)		2,72	2,62	2,72	2,80	2,87	2,75
Compressors								
Compressors/Circuits	(8)	n°/n°	2/2	2/2	2/2	2/2	2/2	2/2
Minimum capacity reduction step		%	12%	12%	13%	12%	13%	12%
Refrigerant charge (CH + MCHX)		kg	52	63	70	75	83	83
Refrigerant charge (CH + CuAl)		kg	108	126	140	152	167	167
Fans								
Quantity		n°	8	9	10	11	12	12
Total air flow rate		m³/h	168000	189000	210000	231000	252000	252000
User-side heat exchanger								
Quantity		n°	1	1	1	1	1	1
Water flow rate (CH) (A35; W7)	(1)	m³/h	97,0	104,2	117,2	126,6	133,2	142,1
Head loss (CH) (A35; W7)	(1)	kPa	48	35	42	47	32	36
Noise levels								
Sound power level cooling	(3)	dB(A)	98	98	99	100	100	100
Sound pressure level cooling	(4)	dB(A)	66	66	67	67	67	68
Sound power level of vers. LN cooling	(3)	dB(A)	93	93	94	95	95	95
Sound pressure level of vers. LN cooling	(4)	dB(A)	61	60	62	63	63	63
Dimensions and weights**								
Length		mm	5.020	6.165	6.165	7.310	7.310	7.310
Depth		mm	2.260	2.260	2.260	2.260	2.260	2.260
Height		mm	2.440	2.440	2.440	2.440	2.440	2.440
Operating weight CH (MCHX)	(5)	kg	4.150	5.090	5.520	6.070	6.430	6.480

(CH: chiller unit; HP: heat pump unit; MCHX: unit with microchannel coils; CuAl: unit with copper/aluminium tube/fin coils)

(1) Outside air temperature 35°C; evaporator inlet-outlet water temperature 12/7°C. Values compliant with standard EN 14511

(2) Outside air temperature 7°C DB, 6°C WB; condenser inlet/outlet water temperature 40/45°C. Values compliant with standard EN 14511

(3) Unit operating at nominal operating capacity, without any accessories, with external air temperature of 35°C and user-side heat exchanger water inlet/outlet temperature of 12/7°C. Binding values. Values obtained from measures taken according to standard ISO 3744 and to the Eurovent certification programme where applicable.

(4) Values obtained from the sound power level (conditions: note 2), related to a distance of 10 m from the unit in free field with directivity factor Q=2. Non-binding values.

(5) The weight refers to the unit without any accessory. The introduction of a few accessories such as copper/aluminum coils, hydraulic modules or the recovery exchangers can lead to weight increased that can exceed 10%. For further details refer to the specific drawing of the selected configuration.

(8) Approximate value. The minimum capacity reached by the unit depends on the operating conditions. The value shown may not be suitable for calculating the minimum volume of water: to do this, consult the "Minimum water content in the system" section.

** Basic CH unit without included accessories

KAPPA REV (R513A)

			90.2	95.2	100.2	105.2	115.2	120.2	130.2
KAPPA REV (R513A)									
Cooling (A35; W7)									
Refrigeration capacity	(1)	kW	892	938	980	1040	1111	1185	1274
Total absorbed power	(1)	kW	336	352	370	384	401	433	455
EER	(1)		2,65	2,66	2,64	2,70	2,77	2,73	2,80
Compressors									
Compressors/Circuits	(8)	n°/n°	2/2	2/2	2/2	2/2	2/2	2/2	2/2
Minimum capacity reduction step		%	13%	12%	12%	12%	12%	12%	7%
Refrigerant charge (CH + MCHX)		kg	87	98	102	115	122	132	136
Refrigerant charge (CH + CuAl)		kg	171	189	200	220	234	258	262
Fans									
Quantity		n°	12	13	14	15	16	18	18
Total air flow rate		m³/h	252000	273000	294000	315000	336000	378000	378000
User-side heat exchanger									
Quantity		n°	1	1	1	1	1	1	1
Water flow rate (CH) (A35; W7)	(1)	m³/h	153,4	161,3	168,6	178,9	191,1	203,8	219,1
Head loss (CH) (A35; W7)	(1)	kPa	42	49	54	49	25	29	32
Noise levels									
Sound power level cooling	(3)	dB(A)	100	101	101	102	102	102	103
Sound pressure level cooling	(4)	dB(A)	68	68	68	69	69	69	70
Sound power level of vers. LN cooling	(3)	dB(A)	95	96	96	97	97	97	98
Sound pressure level of vers. LN cooling	(4)	dB(A)	62	63	63	64	64	64	65
Dimensions and weights**									
Length		mm	7.310	8.465	8.465	9.610	9.610	10.755	10.755
Depth		mm	2.260	2.260	2.260	2.260	2.260	2.260	2.260
Height		mm	2.440	2.440	2.440	2.440	2.440	2.440	2.440
Operating weight CH (MCHX)	(5)	kg	6.560	6.900	6.940	7.490	8.010	8.420	8.560

(CH: chiller unit; HP: heat pump unit; MCHX: unit with microchannel coils; CuAl: unit with copper/aluminium tube/fin coils)

(1) Outside air temperature 35°C; evaporator inlet-outlet water temperature 12/7°C. Values compliant with standard EN 14511

(2) Outside air temperature 7°C DB, 6°C WB; condenser inlet/outlet water temperature 40/45°C. Values compliant with standard EN 14511

(3) Unit operating at nominal operating capacity, without any accessories, with external air temperature of 35°C and user-side heat exchanger water inlet/outlet temperature of 12/7°C. Binding values. Values obtained from measures taken according to standard ISO 3744 and to the Eurovent certification programme where applicable.

(4) Values obtained from the sound power level (conditions: note 2), related to a distance of 10 m from the unit in free field with directivity factor Q=2. Non-binding values.

(5) The weight refers to the unit without any accessory. The introduction of a few accessories such as copper/aluminum coils, hydraulic modules or the recovery exchangers can lead to weight increased that can exceed 10%. For further details refer to the specific drawing of the selected configuration.

(8) Approximate value. The minimum capacity reached by the unit depends on the operating conditions. The value shown may not be suitable for calculating the minimum volume of water: to do this, consult the "Minimum water content in the system" section.

** Basic CH unit without included accessories

KAPPA REV (R513A)

			140.3	150.3	160.3	170.4	180.4	190.4	200.4
KAPPA REV (R513A)									
Cooling (A35; W7)									
Refrigeration capacity	(1)	kW	1398	1469	1512	1653	1785	1876	1961
Total absorbed power	(1)	kW	528	554	567	599	671	703	740
EER	(1)		2,65	2,65	2,66	2,75	2,66	2,66	2,64
Compressors									
Compressors/Circuits	(8)	n°/n°	3/3	3/3	3/3	4/4	4/4	4/4	4/4
Minimum capacity reduction step		%	8%	8%	8%	6%	6%	6%	6%
Refrigerant charge (CH + MCHX)		kg	149	160	165	167	174	195	205
Refrigerant charge (CH + CuAl)		kg	289	307	319	335	342	377	401
Fans									
Quantity		n°	20	21	22	24	24	26	28
Total air flow rate		m³/h	420000	441000	462000	504000	504000	546000	588000
User-side heat exchanger									
Quantity		n°	1	1	1	2	2	2	2
Water flow rate (CH) (A35; W7)	(1)	m³/h	240,4	252,7	260,1	284,2	306,9	322,6	337,3
Head loss (CH) (A35; W7)	(1)	kPa	39	34	36	36	42	49	54
Noise levels									
Sound power level cooling	(3)	dB(A)	104	105	106	103	103	104	104
Sound pressure level cooling	(4)	dB(A)	71	71	72	71	71	71	71
Sound power level of vers. LN cooling	(3)	dB(A)	99	100	101	98	98	99	99
Sound pressure level of vers. LN cooling	(4)	dB(A)	66	67	68	66	65	66	66
Dimensions and weights**									
Length		mm	11.965	13.110	13.110	2 x 7.310	2 x 7.310	2 x 8.465	2 x 8.465
Depth		mm	2.260	2.260	2.260	2.260	2.260	2.260	2.260
Height		mm	2.440	2.440	2.440	2.440	2.440	2.440	2.440
Operating weight CH (MCHX)	(5)	kg				2 x 6.480	2 x 6.560	2 x 6.900	2 x 6.940

(CH: chiller unit; HP: heat pump unit; MCHX: unit with microchannel coils; CuAl: unit with copper/aluminium tube/fin coils)

(1) Outside air temperature 35°C; evaporator inlet-outlet water temperature 12/7°C. Values compliant with standard EN 14511

(2) Outside air temperature 7°C DB, 6°C WB; condenser inlet/outlet water temperature 40/45°C. Values compliant with standard EN 14511

(3) Unit operating at nominal operating capacity, without any accessories, with external air temperature of 35°C and user-side heat exchanger water inlet/outlet temperature of 12/7°C. Binding values. Values obtained from measures taken according to standard ISO 3744 and to the Eurovent certification programme where applicable.

(4) Values obtained from the sound power level (conditions: note 2), related to a distance of 10 m from the unit in free field with directivity factor Q=2. Non-binding values.

(5) The weight refers to the unit without any accessory. The introduction of a few accessories such as copper/aluminum coils, hydraulic modules or the recovery exchangers can lead to weight increased that can exceed 10%. For further details refer to the specific drawing of the selected configuration.

(8) Approximate value. The minimum capacity reached by the unit depends on the operating conditions. The value shown may not be suitable for calculating the minimum volume of water: to do this, consult the "Minimum water content in the system" section.

** Basic CH unit without included accessories

KAPPA REV HE (R513A)

			33.2	35.2	37.2	40.2	43.2	51.2	54.2
KAPPA REV HE (R513A)									
Cooling (A35; W7)									
Refrigeration capacity	(1)	kW	335	384	405	462	511	521	580
Total absorbed power	(1)	kW	107	122	127	148	166	170	188
EER	(1)		3,13	3,15	3,17	3,11	3,06	3,06	3,08
Compressors									
Compressors/Circuits		n°/n°	2/2	2/2	2/2	2/2	2/2	2/2	2/2
Minimum capacity reduction step	(8)	%	12%	12%	13%	11%	13%	12%	12%
Refrigerant charge (CH + MCHX)		kg	58	66	70	79	88	90	100
Refrigerant charge (CH + CuAl)		kg	37	21	24	36	41	27	32
Fans									
Quantity		n°	6	7	8	8	8	9	11
Total air flow rate		m³/h	126000	147000	168000	168000	168000	189000	231000
User-side heat exchanger									
Quantity		n°	1	1	1	1	1	1	1
Water flow rate (CH) (A35; W7)	(1)	m³/h	57,6	66,1	69,6	79,4	87,8	89,6	99,8
Head loss (CH) (A35; W7)	(1)	kPa	36	20	23	35	41	26	32
Noise levels									
Sound power level cooling	(3)	dB(A)	94	95	95	96	96	97	98
Sound pressure level cooling	(4)	dB(A)	62	62	62	63	63	65	66
Sound power level of vers. LN cooling	(3)	dB(A)	89	90	90	91	91	92	93
Sound pressure level of vers. LN cooling	(4)	dB(A)	57	58	58	59	59	59	61
Dimensions and weights**									
Length		mm	3.870	5.020	5.020	5.020	5.020	6.165	7.310
Depth		mm	2.260	2.260	2.260	2.260	2.260	2.260	2.260
Height		mm	2.440	2.440	2.440	2.440	2.440	2.440	2.440
Operating weight CH (MCHX)	(5)	kg	3.070	3.500	3.510	3.830	4.140	4.660	5.210

(CH: chiller unit; HP: heat pump unit; MCHX: unit with microchannel coils; CuAl: unit with copper/aluminium tube/fin coils)

(1) Outside air temperature 35°C; evaporator inlet-outlet water temperature 12/7°C. Values compliant with standard EN 14511

(2) Outside air temperature 7°C DB, 6°C WB; condenser inlet/outlet water temperature 40/45°C. Values compliant with standard EN 14511

(3) Unit operating at nominal operating capacity, without any accessories, with external air temperature of 35°C and user-side heat exchanger water inlet/outlet temperature of 12/7°C. Binding values. Values obtained from measures taken according to standard ISO 3744 and to the Eurovent certification programme where applicable.

(4) Values obtained from the sound power level (conditions: note 2), related to a distance of 10 m from the unit in free field with directivity factor Q=2. Non-binding values.

(5) The weight refers to the unit without any accessory. The introduction of a few accessories such as copper/aluminum coils, hydraulic modules or the recovery exchangers can lead to weight increased that can exceed 10%. For further details refer to the specific drawing of the selected configuration.

(8) Approximate value. The minimum capacity reached by the unit depends on the operating conditions. The value shown may not be suitable for calculating the minimum volume of water: to do this, consult the "Minimum water content in the system" section.

** Basic CH unit without included accessories

KAPPA REV HE (R513A)

			58.2	67.2	73.2	80.2	85.2	90.2	95.2
KAPPA REV HE (R513A)									
Cooling (A35; W7)									
Refrigeration capacity	(1)	kW	675	732	772	814	888	959	1013
Total absorbed power	(1)	kW	222	241	251	266	289	310	333
EER	(1)		3,04	3,03	3,07	3,06	3,07	3,09	3,04
Compressors									
Compressors/Circuits		n°/n°	2/2	2/2	2/2	2/2	2/2	2/2	2/2
Minimum capacity reduction step	(8)	%	12%	13%	12%	13%	12%	13%	12%
Refrigerant charge (CH + MCHX)		kg	116	126	133	140	152	164	174
Refrigerant charge (CH + CuAl)		kg	25	28	32	36	43	50	48
Fans									
Quantity		n°	12	12	13	14	15	16	17
Total air flow rate		m³/h	252000	252000	273000	294000	315000	336000	357000
User-side heat exchanger									
Quantity		n°	1	1	1	1	1	1	1
Water flow rate (CH) (A35; W7)	(1)	m³/h	116,1	125,8	132,8	139,9	152,7	164,9	174,2
Head loss (CH) (A35; W7)	(1)	kPa	25	28	31	35	43	50	47
Noise levels									
Sound power level cooling	(3)	dB(A)	98	99	100	100	100	100	101
Sound pressure level cooling	(4)	dB(A)	66	67	67	67	67	67	68
Sound power level of vers. LN cooling	(3)	dB(A)	93	94	95	95	95	95	96
Sound pressure level of vers. LN cooling	(4)	dB(A)	60	62	62	62	62	62	63
Dimensions and weights**									
Length		mm	7.310	7.310	8.465	8.465	9.610	9.610	10.755
Depth		mm	2.260	2.260	2.260	2.260	2.260	2.260	2.260
Height		mm	2.440	2.440	2.440	2.440	2.440	2.440	2.440
Operating weight CH (MCHX)	(5)	kg	6.000	6.410	6.740	6.760	7.140	7.220	8.420

(CH: chiller unit; HP: heat pump unit; MCHX: unit with microchannel coils; CuAl: unit with copper/aluminium tube/fin coils)

(1) Outside air temperature 35°C; evaporator inlet-outlet water temperature 12/7°C. Values compliant with standard EN 14511

(2) Outside air temperature 7°C DB, 6°C WB; condenser inlet/outlet water temperature 40/45°C. Values compliant with standard EN 14511

(3) Unit operating at nominal operating capacity, without any accessories, with external air temperature of 35°C and user-side heat exchanger water inlet/outlet temperature of 12/7°C. Binding values. Values obtained from measures taken according to standard ISO 3744 and to the Eurovent certification programme where applicable.

(4) Values obtained from the sound power level (conditions: note 2), related to a distance of 10 m from the unit in free field with directivity factor Q=2. Non-binding values.

(5) The weight refers to the unit without any accessory. The introduction of a few accessories such as copper/aluminum coils, hydraulic modules or the recovery exchangers can lead to weight increased that can exceed 10%. For further details refer to the specific drawing of the selected configuration.

(8) Approximate value. The minimum capacity reached by the unit depends on the operating conditions. The value shown may not be suitable for calculating the minimum volume of water: to do this, consult the "Minimum water content in the system" section.

** Basic CH unit without included accessories

KAPPA REV HE (R513A)

			100.2	105.2	115.2	120.2	134.4	146.4	160.4
KAPPA REV HE (R513A)									
Cooling (A35; W7)									
Refrigeration capacity	(1)	kW	1075	1147	1222	1321	1448	1524	1601
Total absorbed power	(1)	kW	353	366	381	420	479	502	527
EER	(1)		3,05	3,13	3,20	3,14	3,02	3,03	3,04
Compressors									
Compressors/Circuits		n°/n°	2/2	2/2	2/2	2/2	4/4	4/4	4/4
Minimum capacity reduction step	(8)	%	13%	12%	13%	13%	6%	6%	6%
Refrigerant charge (CH + MCHX)		kg	184	197	210	227	249	262	275
Refrigerant charge (CH + CuAl)		kg	53	26	29	33	28	32	36
Fans									
Quantity		n°	18	19	21	22	24	26	28
Total air flow rate		m³/h	378000	399000	441000	462000	504000	546000	588000
User-side heat exchanger									
Quantity		n°	1	1	1	1	2	2	2
Water flow rate (CH) (A35; W7)	(1)	m³/h	184,9	197,3	210,2	227,2	249,1	262,0	275,4
Head loss (CH) (A35; W7)	(1)	kPa	52	25	28	32	28	31	35
Noise levels									
Sound power level cooling	(3)	dB(A)	101	102	102	102	102	103	103
Sound pressure level cooling	(4)	dB(A)	68	69	69	69	70	70	70
Sound power level of vers. LN cooling	(3)	dB(A)	96	97	97	97	97	98	98
Sound pressure level of vers. LN cooling	(4)	dB(A)	63	64	64	64	65	65	65
Dimensions and weights**									
Length		mm	10.755	11.965	13.110	13.110	2 x 7.310	2 x 8.465	2 x 8.465
Depth		mm	2.260	2.260	2.260	2.260	2.260	2.260	2.260
Height		mm	2.440	2.440	2.440	2.440	2.440	2.440	2.440
Operating weight CH (MCHX)	(5)	kg	8.560	8.810	9.350	9.410	2 x 6.410	2 x 6.740	2 x 6.760

(CH: chiller unit; HP: heat pump unit; MCHX: unit with microchannel coils; CuAl: unit with copper/aluminium tube/fin coils)

(1) Outside air temperature 35°C; evaporator inlet-outlet water temperature 12/7°C. Values compliant with standard EN 14511

(2) Outside air temperature 7°C DB, 6°C WB; condenser inlet/outlet water temperature 40/45°C. Values compliant with standard EN 14511

(3) Unit operating at nominal operating capacity, without any accessories, with external air temperature of 35°C and user-side heat exchanger water inlet/outlet temperature of 12/7°C. Binding values. Values obtained from measures taken according to standard ISO 3744 and to the Eurovent certification programme where applicable.

(4) Values obtained from the sound power level (conditions: note 2), related to a distance of 10 m from the unit in free field with directivity factor Q=2. Non-binding values.

(5) The weight refers to the unit without any accessory. The introduction of a few accessories such as copper/aluminum coils, hydraulic modules or the recovery exchangers can lead to weight increased that can exceed 10%. For further details refer to the specific drawing of the selected configuration.

(8) Approximate value. The minimum capacity reached by the unit depends on the operating conditions. The value shown may not be suitable for calculating the minimum volume of water: to do this, consult the "Minimum water content in the system" section.

** Basic CH unit without included accessories

KAPPA REV SLN (R513A)

			33.2	35.2	37.2	40.2	43.2	51.2	54.2
KAPPA REV SLN (R513A)									
Cooling (A35; W7)									
Refrigeration capacity	(1)	kW	330	372	395	457	499	513	567
Total absorbed power	(1)	kW	109	124	129	150	167	171	188
EER	(1)		3,01	3,00	3,05	3,05	2,99	3,00	3,02
Compressors									
Compressors/Circuits		n°/n°	2/2	2/2	2/2	2/2	2/2	2/2	2/2
Minimum capacity reduction step	(8)	%	12%	12%	13%	11%	13%	12%	12%
Refrigerant charge (CH + MCHX)		kg	46	52	52	56	56	68	77
Refrigerant charge (CH + CuAl)		kg	88	101	108	112	112	131	154
Fans									
Quantity		n°	6	7	8	8	8	9	11
Total air flow rate		m³/h	96000	112000	128000	128000	128000	144000	176000
User-side heat exchanger									
Quantity		n°	1	1	1	1	1	1	1
Water flow rate (CH) (A35; W7)	(1)	m³/h	56,7	64,0	68,0	78,7	85,9	88,3	97,6
Head loss (CH) (A35; W7)	(1)	kPa	34	19	22	33	38	24	30
Noise levels									
Sound power level cooling	(3)	dB(A)	86	87	87	88	88	89	90
Sound pressure level cooling	(4)	dB(A)	54	55	54	56	56	57	58
Dimensions and weights**									
Length		mm	3.870	5.020	5.020	5.020	5.020	6.165	7.310
Depth		mm	2.260	2.260	2.260	2.260	2.260	2.260	2.260
Height		mm	2.440	2.440	2.440	2.440	2.440	2.440	2.440
Operating weight CH (MCHX)	(5)	kg	3.070	3.500	3.510	3.830	4.140	4.660	5.210

(CH: chiller unit; HP: heat pump unit; MCHX: unit with microchannel coils; CuAl: unit with copper/aluminium tube/fin coils)

(1) Outside air temperature 35°C; evaporator inlet-outlet water temperature 12/7°C. Values compliant with standard EN 14511

(2) Outside air temperature 7°C DB, 6°C WB; condenser inlet/outlet water temperature 40/45°C. Values compliant with standard EN 14511

(3) Unit operating at nominal operating capacity, without any accessories, with external air temperature of 35°C and user-side heat exchanger water inlet/outlet temperature of 12/7°C. Binding values. Values obtained from measures taken according to standard ISO 3744 and to the Eurovent certification programme where applicable.

(4) Values obtained from the sound power level (conditions: note 2), related to a distance of 10 m from the unit in free field with directivity factor Q=2. Non-binding values.

(5) The weight refers to the unit without any accessory. The introduction of a few accessories such as copper/aluminum coils, hydraulic modules or the recovery exchangers can lead to weight increased that can exceed 10%. For further details refer to the specific drawing of the selected configuration.

(8) Approximate value. The minimum capacity reached by the unit depends on the operating conditions. The value shown may not be suitable for calculating the minimum volume of water: to do this, consult the "Minimum water content in the system" section.

** Basic CH unit without included accessories

KAPPA REV SLN (R513A)

			58.2	67.2	73.2	80.2	85.2	90.2	95.2
KAPPA REV SLN (R513A)									
Cooling (A35; W7)									
Refrigeration capacity	(1)	kW	670	731	758	801	883	944	1013
Total absorbed power	(1)	kW	222	244	253	266	293	315	337
EER	(1)		3,01	2,99	2,99	3,00	3,01	2,99	3,00
Compressors									
Compressors/Circuits		n°/n°	2/2	2/2	2/2	2/2	2/2	2/2	2/2
Minimum capacity reduction step	(8)	%	12%	13%	12%	13%	12%	13%	12%
Refrigerant charge (CH + MCHX)		kg	83	83	92	92	105	111	128
Refrigerant charge (CH + CuAl)		kg	167	167	183	190	210	223	247
Fans									
Quantity		n°	12	12	13	14	15	16	17
Total air flow rate		m³/h	192000	192000	208000	224000	240000	256000	272000
User-side heat exchanger									
Quantity		n°	1	1	1	1	1	1	1
Water flow rate (CH) (A35; W7)	(1)	m³/h	115,2	125,8	130,4	137,7	152,0	162,5	174,2
Head loss (CH) (A35; W7)	(1)	kPa	23	26	29	33	40	47	44
Noise levels									
Sound power level cooling	(3)	dB(A)	90	91	92	92	92	92	93
Sound pressure level cooling	(4)	dB(A)	58	59	59	59	59	59	60
Dimensions and weights**									
Length		mm	7.310	7.310	8.465	8.465	9.610	9.610	10.755
Depth		mm	2.260	2.260	2.260	2.260	2.260	2.260	2.260
Height		mm	2.440	2.440	2.440	2.440	2.440	2.440	2.440
Operating weight CH (MCHX)	(5)	kg	6.000	6.410	6.740	6.760	7.140	7.220	8.420

(CH: chiller unit; HP: heat pump unit; MCHX: unit with microchannel coils; CuAl: unit with copper/aluminium tube/fin coils)

(1) Outside air temperature 35°C; evaporator inlet-outlet water temperature 12/7°C. Values compliant with standard EN 14511

(2) Outside air temperature 7°C DB, 6°C WB; condenser inlet/outlet water temperature 40/45°C. Values compliant with standard EN 14511

(3) Unit operating at nominal operating capacity, without any accessories, with external air temperature of 35°C and user-side heat exchanger water inlet/outlet temperature of 12/7°C. Binding values. Values obtained from measures taken according to standard ISO 3744 and to the Eurovent certification programme where applicable.

(4) Values obtained from the sound power level (conditions: note 2), related to a distance of 10 m from the unit in free field with directivity factor Q=2. Non-binding values.

(5) The weight refers to the unit without any accessory. The introduction of a few accessories such as copper/aluminum coils, hydraulic modules or the recovery exchangers can lead to weight increased that can exceed 10%. For further details refer to the specific drawing of the selected configuration.

(8) Approximate value. The minimum capacity reached by the unit depends on the operating conditions. The value shown may not be suitable for calculating the minimum volume of water: to do this, consult the "Minimum water content in the system" section.

** Basic CH unit without included accessories

KAPPA REV SLN (R513A)

			100.2	105.2	115.2	120.2	134.4	146.4	160.4
KAPPA REV SLN (R513A)									
Cooling (A35; W7)									
Refrigeration capacity	(1)	kW	1079	1126	1192	1287	1448	1524	1606
Total absorbed power	(1)	kW	359	370	386	425	488	505	532
EER	(1)		3,00	3,04	3,08	3,02	2,96	3,01	3,01
Compressors									
Compressors/Circuits		n°/n°	2/2	2/2	2/2	2/2	4/4	4/4	4/4
Minimum capacity reduction step	(8)	%	13%	12%	13%	13%	6%	6%	6%
Refrigerant charge (CH + MCHX)		kg	128	141	145	154	167	185	185
Refrigerant charge (CH + CuAl)		kg	254	274	292	308	335	367	381
Fans									
Quantity		n°	18	19	21	22	24	26	28
Total air flow rate		m³/h	288000	304000	336000	352000	384000	416000	448000
User-side heat exchanger									
Quantity		n°	1	1	1	1	2	2	2
Water flow rate (CH) (A35; W7)	(1)	m³/h	185,7	193,7	205,0	221,5	249,2	262,1	276,4
Head loss (CH) (A35; W7)	(1)	kPa	49	23	26	30	26	29	33
Noise levels									
Sound power level cooling	(3)	dB(A)	93	94	94	94	94	95	95
Sound pressure level cooling	(4)	dB(A)	60	61	61	61	62	62	62
Dimensions and weights**									
Length		mm	10.755	11.965	13.110	13.110	2 x 7.310	2 x 8.465	2 x 8.465
Depth		mm	2.260	2.260	2.260	2.260	2.260	2.260	2.260
Height		mm	2.440	2.440	2.440	2.440	2.440	2.440	2.440
Operating weight CH (MCHX)	(5)	kg	8.560	8.810	9.350	9.410	2 x 6.410	2 x 6.740	2 x 6.760

(CH: chiller unit; HP: heat pump unit; MCHX: unit with microchannel coils; CuAl: unit with copper/aluminium tube/fin coils)

(1) Outside air temperature 35°C; evaporator inlet-outlet water temperature 12/7°C. Values compliant with standard EN 14511

(2) Outside air temperature 7°C DB, 6°C WB; condenser inlet/outlet water temperature 40/45°C. Values compliant with standard EN 14511

(3) Unit operating at nominal operating capacity, without any accessories, with external air temperature of 35°C and user-side heat exchanger water inlet/outlet temperature of 12/7°C. Binding values. Values obtained from measures taken according to standard ISO 3744 and to the Eurovent certification programme where applicable.

(4) Values obtained from the sound power level (conditions: note 2), related to a distance of 10 m from the unit in free field with directivity factor Q=2. Non-binding values.

(5) The weight refers to the unit without any accessory. The introduction of a few accessories such as copper/aluminum coils, hydraulic modules or the recovery exchangers can lead to weight increased that can exceed 10%. For further details refer to the specific drawing of the selected configuration.

(8) Approximate value. The minimum capacity reached by the unit depends on the operating conditions. The value shown may not be suitable for calculating the minimum volume of water: to do this, consult the "Minimum water content in the system" section.

** Basic CH unit without included accessories

ECODESIGN

INTRODUCTION

The Ecodesign/ErP Directive (2009/125/EC) lays down new standards for more efficient energy use.

The Directive contains various regulations; as regards chiller products and heat pumps, the regulations of interest are the following:

- Regulation 2013/813, for small heat pumps ($P_{\text{design}} \leq 400$ kW)
- Regulation 2016/2281, for chillers and heat pumps with $P_{\text{design}} > 400$ kW
- Regulation 2013/811, for heat pumps with $P_{\text{design}} \leq 70$ kW.

The last-mentioned regulation (2013/811) regards the labelling (Ecolabel certification) of small heat pumps.

The other two regulations (2013/813 and 2016/2281) set seasonal efficiency targets that the products must comply with to be sold and installed in the European Union (essential requirement for CE marking).

These efficiency limits are defined through ratios, which are respectively:

- η_{sh} (SCOP), with reference to regulation 2013/813
- η_{sc} (SEER) for comfort applications and SEPR for process applications, with reference to regulation 2016/2281.

As regards regulation 2016/2281, with effect from 1st January 2021, the required minimum efficiency limit will be raised (Tier 2) from the current threshold (Tier 1).

The figure below schematically illustrates the correspondence between product and reference energy ratio.

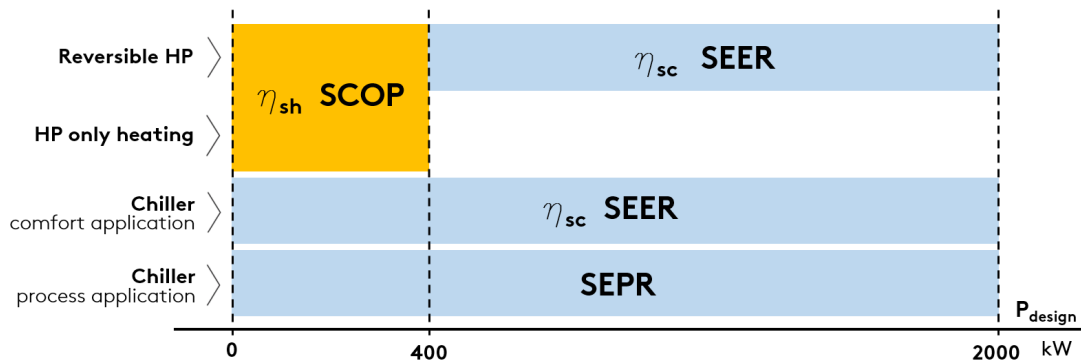

Some notes and clarifications:

For comfort applications, regulation 2016/2281 sets the η_{sc} (SEER) ratio in two different operating conditions:

- SEER calculated with machine inlet/outlet water temperature of 12/7°C (low temperature application),
- SEER calculated with machine inlet/outlet water temperature of 23/18°C (medium temperature application).

The minimum efficiency requirement is the same, but can be met at condition 12/7°C or at condition 23/18°C, depending on the application envisaged for the machine.

Regulation 2013/813 distinguishes two different types: at low temperature and at medium temperature.

The following refer to the application at low temperature: (low temperature application) all heat pumps whose maximum delivery temperature for heating purposes is lower than 52°C with source at temperature of -7°C and -8°C wet bulb (air-water unit) or inlet 10°C (water-water unit), at the reference design conditions for an average climate. For these, the efficiency ratio is "low temperature application" (outlet water temperature 35°C).

For all the other heat pumps, the efficiency ratio is related to "medium temperature application" (outlet water temperature 55°C).

The ratios must be calculated according to the reference European heating season in average climatic conditions.

The minimum efficiency requirements set by the regulations are indicated below.

REGULATION 2016/2281, comfort application

TYPE OF UNIT		MINIMUM REQUIREMENT			
		Tier 1		Tier 2 (2021)	
SOURCE	P _{design}	η_{sc} [%]	SEER	η_{sc} [%]	SEER
air	< 400kW	149	3,8	161	4,1
air	\geq 400kW	161	4,1	179	4,55
water	< 400kW	196	5,1	200	5,2
water	\geq 400kW and < 1500kW	227	5,875	252	6,5
water	\geq 1500kW	245	6,325	272	7

REGULATION 2016/2281, process application

TYPE OF UNIT		MINIMUM REQUIREMENT	
		Tier 1	Tier 2 (2021)
SOURCE	P _{design}	SEPR	SEPR
air	< 400kW	4,5	5
air	\geq 400kW	5	5,5
water	< 400kW	6,5	7
water	\geq 400kW and < 1500kW	7,5	8
water	\geq 1500kW	8	8,5

REGULATION 2013/813

SOURCE	APPLICATION	MINIMUM REQUIREMENT	
		η_{sh} [%]	SCOP
air	low temperature application	125	3,2
water	low temperature application	125	3,325
air	medium temperature application	110	2,825
water	medium temperature application	110	2,95

The conformity of the product must be checked according to the type of application, whether comfort or process, and at the required outlet water temperature.

The two schematic tables below, respectively for comfort application and for process application, indicate the reference of the required conformity according to the type of product and the set point temperature (reference to regulations 2016/2281 and 2013/813).

Important note: for mixed comfort and process applications, the reference application for conformity is the comfort application.

COMFORT APPLICATION

PRODUCT	OUTLET WATER TEMPERATURE	COMPLIANCE INDEX	REGULATION
Chiller	< 18°C	SEER/η _{sc} low temperature application	2016/2281
	≥ 18°C	SEER/η _{sc} medium temperature application	2016/2281
Heat pumps (reversible and only heating) P_{design} ≤ 400kW		SCOP/η _{sh}	2013/813
Reversible heat pumps P_{design} > 400kW	< 18°C	SEER/η _{sc} low temperature application	2016/2281
	≥ 18°C	SEER/η _{sc} medium temperature application	2016/2281
Heat pumps only heating P_{design} > 400kW		-	-

PROCESS APPLICATION

PRODUCT	OUTLET WATER TEMPERATURE	COMPLIANCE INDEX	REGULATION
Chiller	≥ +2°C , ≤ 12°C	SEPR	2016/2281
	> 12°C	-	-
	> -8°C , < +2°C	-	-

- = exemption from Ecodesign

Some specifications and notes follow.

Partly completed machinery

The term partly completed machinery refers to all units without a user-side or source-side heat exchanger, and therefore to all LC, LE, LC/HP and LE/HP versions. Since these are "non-complete" machines, conformity with Ecodesign depends on combination with the remote heat exchanger.

All the partly completed machinery is CE marked and accompanied by a declaration of conformity. Installation in European Union countries is therefore allowed; correct selection and installation of the remote heat exchanger must be ensured, in accordance with the above cases.

EC fans:

The only option that positively affects the performance of the unit, by increasing its seasonal energy efficiency ratio, is the VEC accessory.

A unit equipped with EC fans has a higher SEER (η_{sc}) than the configuration with standard fans.

KAPPA REV RANGE

As specifically regards the Zeta Rev range, the regulations of interest for the various units in various configurations are indicated below.

Kappa Rev:

- chiller version: regulation 2016/2281.
- /HP version: up to size 37.2 regulation 2013/813 from size 40.2 together with sizes 108.4, 116.4, 134.4, 146.4, 160.4, regulation 2016/2281.

Kappa Rev HE and Kappa Rev SLN:

- chiller version: regulation 2016/2281
- /HP version: up to size 37.2 regulation 2013/813, from size 40.2 together with sizes 108.4, 116.4, 134.4, 146.4, 160.4, regulation 2016/2281.

The tables below give information on the conformity of the units and the seasonal energy performance ratios with regard to the reference regulation.

KAPPA REV

			33.2	35.2	37.2	40.2	43.2	51.2	54.2
REGULATION 2016/2281									
Pdesign	(1)	kW	308	340	373	410	459	483	539
Compliance 12/7									
η _{sc}	(1)	%	-	-	-	-	-	-	-
SEER	(1)		-	-	-	-	-	-	-
Compliance Tier 2 (2021)	(1)		N	N	N	N	N	N	N
Compliance 12/7 unit with EC fans									
η _{sc}	(1)	%	158	153,3	154,2	-	-	-	-
SEER	(1)		4,02	3,9	3,92	-	-	-	-
Compliance Tier 2 (2021)	(1)		N	N	N	N	N	N	N
Compliance 23/18									
η _{sc}	(2)	%	177,8%	177,8%	170,2%	172,2%	170,2%	171,0%	171,4%
SEER	(2)		4,52	4,52	4,33	4,38	4,33	4,35	4,36
Compliance Tier 2 (2021)	(2)		Y	Y	Y	N	N	N	N
Compliance SEPR									
SEPR	(3)		5,18	5,46	5,37	5,13	5,05	5,02	5,03
Compliance Tier 2 (2021)	(3)		Y	Y	Y	N	N	N	N

Y = unit in compliance with Ecodesign at the indicated condition.

			58.2	67.2	73.2	80.2	85.2	90.2	95.2
REGULATION 2016/2281									
Pdesign	(1)	kW	612	689	736	787	840	890	952
Compliance 12/7									
η _{sc}	(1)	%	-	-	-	-	-	-	-
SEER	(1)		-	-	-	-	-	-	-
Compliance Tier 2 (2021)	(1)		N	N	N	N	N	N	N
Compliance 12/7 unit with EC fans									
η _{sc}	(1)	%	-	-	-	-	-	-	-
SEER	(1)		-	-	-	-	-	-	-
Compliance Tier 2 (2021)	(1)		N	N	N	N	N	N	N
Compliance 23/18									
η _{sc}	(2)	%	173,0%	173,0%	172,6%	176,2%	173,4%	174,2%	176,6%
SEER	(2)		4,40	4,40	4,39	4,48	4,41	4,43	4,49
Compliance Tier 2 (2021)	(2)		N	N	N	N	N	N	N
Compliance SEPR									
SEPR	(3)		5,1	5,13	5,1	5	5,13	5,07	5,1
Compliance Tier 2 (2021)	(3)		N	N	N	N	N	N	N

Y = unit in compliance with Ecodesign at the indicated condition.

N = unit not in compliance with Ecodesign at the given condition: it can be installed only in non-EU countries.

- = value not necessary: conformity is already provided at the most restrictive condition (1).

(1) User-side heat exchanger water inlet/outlet temperature 12/7°C (low temperature application), with reference to regulation 2016/2281 and standard EN 14825.

(2) User-side heat exchanger water inlet/outlet temperature 23/18°C (medium temperature application), with reference to regulation 2016/2281 and standard EN 14825.

(3) User-side heat exchanger water inlet/outlet temperature 12/7°C, with reference to regulation 2016/2281 and norm EN 14825.

KAPPA REV

			100.2	105.2	115.2	120.2	130.2	140.3	150.3	160.3
REGULATION 2016/2281										
Pdesign	(1)	kW	995	1047	1115	1203	1291	1442	1500	1546
Compliance 12/7										
η_{sc}	(1)	%	-	-	-	-	-	-	-	-
SEER	(1)		-	-	-	-	-	-	-	-
Compliance Tier 2 (2021)	(1)		N	N	N	N	N	N	N	N
Compliance 12/7 unit with EC fans										
η_{sc}	(1)	%	-	-	-	-	-	-	-	-
SEER	(1)		-	-	-	-	-	-	-	-
Compliance Tier 2 (2021)	(1)		N	N	N	N	N	N	N	N
Compliance 23/18										
η_{sc}	(2)	%	176,2%	170,2%	170,6%	175,0%	178,2%	174,2%	176,2%	176,6%
SEER	(2)		4,48	4,33	4,34	4,45	4,53	4,43	4,48	4,49
Compliance Tier 2 (2021)	(2)		N	N	N	N	N	N	N	N
Compliance SEPR										
SEPR	(3)		5,06	5,02	5,02	5,27	5,14	5,05	5,14	5,04
Compliance Tier 2 (2021)	(3)		N	N	N	N	N	N	N	N

Y = unit in compliance with Ecodesign at the indicated condition.

KAPPA REV

			170.4	180.4	190.4	200.4
REGULATION 2016/2281						
Pdesign	(1)	kW	1679	1779	1904	1990
Compliance 12/7						
η_{sc}	(1)	%	-	-	-	-
SEER	(1)		-	-	-	-
Compliance Tier 2 (2021)	(1)		N	N	N	N
Compliance 12/7 unit with EC fans						
η_{sc}	(1)	%	-	-	-	-
SEER	(1)		-	-	-	-
Compliance Tier 2 (2021)	(1)		-	-	-	-
Compliance 23/18						
η_{sc}	(2)	%	173,4%	173,4%	176,6%	176,2%
SEER	(2)		4,41	4,41	4,49	4,48
Compliance Tier 2 (2021)	(2)		N	N	N	N
Compliance SEPR						
SEPR	(3)		5,13	5,07	5,1	5,06
Compliance Tier 2 (2021)	(3)		N	N	N	N

Y = unit in compliance with Ecodesign at the indicated condition.

N = unit not in compliance with Ecodesign at the given condition: it can be installed only in non-EU countries.

- = value not necessary: conformity is already provided at the most restrictive condition (1).

- (1) User-side heat exchanger water inlet/outlet temperature 12/7°C (low temperature application), with reference to regulation 2016/2281 and standard EN 14825.
- (2) User-side heat exchanger water inlet/outlet temperature 23/18°C (medium temperature application), with reference to regulation 2016/2281 and standard EN 14825.
- (3) User-side heat exchanger water inlet/outlet temperature 12/7°C, with reference to regulation 2016/2281 and norm EN 14825.

KAPPA REV /HP

			33.2	35.2	37.2	40.2	43.2	51.2	54.2
REGULATION 2013/813									
Pdesign	(4)	kW	297	329	359	394	440	370	381
Compliance	(4)		Y	Y	Y	Y	Y	Y	Y
η_{sh}	(4)	%	125,2	125	125	125	129,4	125,8	125,4
SCOP	(4)		3,21	3,2	3,2	3,2	3,31	3,27	3,26

Y = unit in compliance with Ecodesign at the indicated condition.

(4) User-side heat exchanger water inlet/outlet temperature 30/35, Average climate profile, with reference to regulation 2013/813 and norm EN 14825.

KAPPA REV /HP

			58.2	67.2	73.2	80.2	85.2	90.2	95.2	100.2
REGULATION 2016/2281										
Pdesign	(1)	kW	588	662	708	758	807	856	915	957
Compliance 12/7										
η_{sc}	(1)	%	-	-	-	-	-	-	-	-
SEER	(1)		-	-	-	-	-	-	-	-
Compliance Tier 2 (2021)	(1)		N	N	N	N	N	N	N	N
Compliance 12/7 unit with EC fans										
η_{sc}	(1)	%	-	-	-	-	-	-	-	-
SEER	(1)		-	-	-	-	-	-	-	-
Compliance Tier 2 (2021)	(1)		N	N	N	N	N	N	N	N
Compliance 23/18										
η_{sc}	(2)	%	166,2	166,2	167,8	169	167,8	167,8	167,8	167,4
SEER	(2)		4,23	4,23	4,27	4,3	4,27	4,27	4,27	4,26
Compliance Tier 2 (2021)	(2)		N	N	N	N	N	N	N	N

KAPPA REV /HP

			108.4	116.4	134.4	146.4	160.4	170.4	180.4	190.4	200.4
REGULATION 2016/2281											
Pdesign	(1)	kW	1037	1175	1324	1415	1515	1614	1711	1831	1914
Compliance 12/7											
η_{sc}	(1)	%	-	-	-	-	-	-	-	-	-
SEER	(1)		-	-	-	-	-	-	-	-	-
Compliance Tier 2 (2021)	(1)		N	N	N	N	N	N	N	N	N
Compliance 12/7 unit with EC fans											
η_{sc}	(1)	%	-	-	-	-	-	-	-	-	-
SEER	(1)		-	-	-	-	-	-	-	-	-
Compliance Tier 2 (2021)	(1)		N	N	N	N	N	N	N	N	N
Compliance 23/18											
η_{sc}	(2)	%	165,8	143,4	151	152,2	159	153,8	153,8	155	154,6
SEER	(2)		4,22	3,66	3,85	3,88	4,05	3,92	3,92	3,95	3,94
Compliance Tier 2 (2021)	(2)		N	N	N	N	N	N	N	N	N

Y = unit in compliance with Ecodesign at the indicated condition.

N = unit not in compliance with Ecodesign at the given condition: it can be installed only in non-EU countries.

- = value not necessary: conformity is already provided at the most restrictive condition (1).

(1) User-side heat exchanger water inlet/outlet temperature 12/7°C (low temperature application), with reference to regulation 2016/2281 and standard EN 14825.

(2) User-side heat exchanger water inlet/outlet temperature 23/18°C (medium temperature application), with reference to regulation 2016/2281 and standard EN 14825.

(3) User-side heat exchanger water inlet/outlet temperature 12/7°C, with reference to regulation 2016/2281 and norm EN 14825.

KAPPA REV HE

			33.2	35.2	37.2	40.2	43.2	51.2	54.2
REGULATION 2016/2281									
Pdesign	(1)	kW	329	367	387	442	492	518	573
Compliance 12/7									
η_{sc}	(1)	%	1,622	1,646	1,614	1,675	1,671	1,671	1,683
SEER	(1)		4,13	4,19	4,11	4,2642	4,2539	4,2539	4,2848
Compliance Tier 2 (2021)	(1)		Y	Y	Y	N	N	N	N
Compliance 12/7 unit with EC fans									
η_{sc}	(1)	%	1,666	1,71	1,682	1,726	1,714	1,734	1,738
SEER	(1)		4,24	4,35	4,28	4,39	4,36	4,41	4,42
Compliance Tier 2 (2021)	(1)		Y	Y	Y	N	N	N	N
Compliance 23/18									
η_{sc}	(2)	%	-	-	-	-	-	-	-
SEER	(2)		-	-	-	-	-	-	-
Compliance SEPR									
Compliance Tier 2 (2021)	(3)		Y	Y	Y	Y	Y	Y	Y
SEPR	(3)		-	-	-	-	-	-	-

Y = unit in compliance with Ecodesign at the indicated condition.

N = unit not in compliance with Ecodesign at the given condition: it can be installed only in non-EU countries.

			58.2	67.2	73.2	80.2	85.2	90.2	95.2
REGULATION 2016/2281									
Pdesign	(1)	kW	674	732	770	813	886	953	1024
Compliance 12/7									
η_{sc}	(1)	%	1,667	1,675	1,675	1,671	1,683	1,671	1,671
SEER	(1)		4,2436	4,2642	4,2642	4,2539	4,2848	4,2539	4,2539
Compliance Tier 2 (2021)	(1)		N	N	N	N	N	N	N
Compliance 12/7 unit with EC fans									
η_{sc}	(1)	%	1,722	1,714	1,718	1,71	1,734	1,718	1,726
SEER	(1)		4,38	4,36	4,37	4,35	4,41	4,37	4,39
Compliance Tier 2 (2021)	(1)		N	N	N	N	N	N	N
Compliance 23/18									
η_{sc}	(2)	%	-	-	-	-	-	-	-
SEER	(2)		-	-	-	-	-	-	-
Compliance SEPR									
Compliance Tier 2 (2021)	(3)		Y	Y	Y	Y	Y	Y	Y
SEPR	(3)		-	-	-	-	-	-	-

Y = unit in compliance with Ecodesign at the indicated condition.

N = unit not in compliance with Ecodesign at the given condition: it can be installed only in non-EU countries.

- = value not necessary: conformity is already provided at the most restrictive condition (1).

- (1) User-side heat exchanger water inlet/outlet temperature 12/7°C (low temperature application), with reference to regulation 2016/2281 and standard EN 14825.
- (2) User-side heat exchanger water inlet/outlet temperature 23/18°C (medium temperature application), with reference to regulation 2016/2281 and standard EN 14825.
- (3) User-side heat exchanger water inlet/outlet temperature 12/7°C, with reference to regulation 2016/2281 and norm EN 14825.

KAPPA REV HE

			100.2	105.2	115.2	120.2	134.4	146.4	160.4
REGULATION 2016/2281									
Pdesign	(1)	kW	1085	1140	1208	1300	1464	1540	1627
Compliance 12/7									
η_{sc}	(1)	%	1,675	1,679	1,683	1,675	1,675	1,675	1,671
SEER	(1)		4,2642	4,2745	4,2848	4,2642	4,2642	4,2642	4,2539
Compliance Tier 2 (2021)	(1)		N	N	N	N	N	N	N
Compliance 12/7 unit with EC fans									
η_{sc}	(1)	%	1,726	1,73	1,73	1,734	1,714	1,722	1,714
SEER	(1)		4,39	4,4	4,4	4,41	4,36	4,38	4,36
Compliance Tier 2 (2021)	(1)		N	N	N	N	N	N	N
Compliance 23/18									
η_{sc}	(2)	%	-	-	-	-	-	-	-
SEER	(2)		-	-	-	-	-	-	-
Compliance SEPR									
Compliance Tier 2 (2021)	(3)		Y	Y	Y	Y	Y	Y	Y
SEPR	(3)		-	-	-	-	-	-	-

Y = unit in compliance with Ecodesign at the indicated condition.

N = unit not in compliance with Ecodesign at the given condition: it can be installed only in non-EU countries.

KAPPA REV HE /HP

			33.2	35.2	37.2	40.2	43.2	51.2
REGULATION 2013/813								
Pdesign	(4)	kW	318	367	396	385	360	385
Compliance	(4)		Y	Y	Y	Y	Y	Y
η_{sh}	(4)	%	130,2	129	127,4	125,8	125,8	125,8
SCOP	(4)		3,33	3,3	3,26	3,22	3,22	3,22

Y = unit in compliance with Ecodesign at the indicated condition.

(4) User-side heat exchanger water inlet/outlet temperature 30/35, Average climate profile, with reference to regulation 2013/813 and norm EN 14825.

KAPPA REV HE /HP

			54.2	58.2	67.2	73.2	80.2	80.4	86.4
REGULATION 2016/2281									
Pdesign	(1)	kW	578	661	704	757	811	867	941
Compliance 12/7									
η_{sc}	(1)	%	162,2	161,8	161,4	161,4	161,4	162,2	162,2
SEER	(1)		4,13	4,12	4,11	4,11	4,11	4,13	4,13
Compliance Tier 2 (2021)	(1)		N	N	N	N	N	N	N
Compliance 12/7 unit with EC fans									
η_{sc}	(1)	%	167,4	167	166,6	166,6	166,6	167,4	167,4
SEER	(1)		4,26	4,25	4,24	4,24	4,24	4,26	4,26
Compliance Tier 2 (2021)	(1)		N	N	N	N	N	N	N

Y = unit in compliance with Ecodesign at the indicated condition.

N = unit not in compliance with Ecodesign at the given condition: it can be installed only in non-EU countries.

- = value not necessary: conformity is already provided at the most restrictive condition (1).

(1) User-side heat exchanger water inlet/outlet temperature 12/7°C (low temperature application), with reference to regulation 2016/2281 and standard EN 14825.

(2) User-side heat exchanger water inlet/outlet temperature 23/18°C (medium temperature application), with reference to regulation 2016/2281 and standard EN 14825.

			102.4	108.4	116.4	134.4	146.4	160.4
REGULATION 2016/2281								
Pdesign	(1)	kW	1008	1156	1322	1407	1515	1623
Compliance 12/7								
η_{sc}	(1)	%	162,6	162,2	161,8	161,4	161,4	162,2
SEER	(1)		4,14	4,13	4,12	4,11	4,11	4,13
Compliance Tier 2 (2021)	(1)		N	N	N	N	N	N
Compliance 12/7 unit with EC fans								
η_{sc}	(1)	%	167,8	167,4	167	166,6	166,6	167,4
SEER	(1)		4,27	4,26	4,25	4,24	4,24	4,26
Compliance Tier 2 (2021)	(1)		N	N	N	N	N	N

Y = unit in compliance with Ecodesign at the indicated condition.

N = unit not in compliance with Ecodesign at the given condition: it can be installed only in non-EU countries.

- = value not necessary: conformity is already provided at the most restrictive condition (1).

(1) User-side heat exchanger water inlet/outlet temperature 12/7°C (low temperature application), with reference to regulation 2016/2281 and standard EN 14825.

(2) User-side heat exchanger water inlet/outlet temperature 23/18°C (medium temperature application), with reference to regulation 2016/2281 and standard EN 14825.

(3) User-side heat exchanger water inlet/outlet temperature 12/7°C, with reference to regulation 2016/2281 and norm EN 14825.

KAPPA REV SLN

			33.2	35.2	37.2	40.2	43.2	51.2	54.2
REGULATION 2016/2281									
Pdesign	(1)	kW	317	354	376	425	472	498	554
Compliance 12/7									
η_{sc}	(1)	%	1,61	163	161,4	167	166,6	166,6	167,8
SEER	(1)		4,1	4,15	4,11	4,25	4,24	4,24	4,27
Compliance Tier 2 (2021)	(1)		Y	Y	Y	N	N	N	N
Compliance 12/7 unit with EC fans									
η_{sc}	(1)	%	1,658	170,2	167,4	171,8	170,6	171,8	172,6
SEER	(1)		4,22	4,33	4,26	4,37	4,34	4,37	4,39
Compliance Tier 2 (2021)	(1)		Y	Y	Y	N	N	N	N
Compliance 23/18									
η_{sc}	(2)	%	-	-	-	-	-	-	-
SEER	(2)		-	-	-	-	-	-	-
Compliance Tier 2 (2021)	(2)		-	-	-	-	-	-	-
Compliance SEPR									
SEPR	(3)		-	-	-	-	-	-	-
Compliance Tier 2 (2021)	(3)		Y	Y	Y	Y	Y	Y	Y

Y = unit in compliance with Ecodesign at the indicated condition.

			58.2	67.2	73.2	80.2	85.2	90.2	95.2
REGULATION 2016/2281									
Pdesign	(1)	kW	648	703	740	783	853	919	986
Compliance 12/7									
η_{sc}	(1)	%	166,2	167	167	166,6	167,8	166,2	166,2
SEER	(1)		4,23	4,25	4,25	4,24	4,27	4,23	4,23
Compliance Tier 2 (2021)	(1)		N	N	N	N	N	N	N
Compliance 12/7 unit with EC fans									
η_{sc}	(1)	%	171,4	170,6	171	170,2	172,2	171	171,4
SEER	(1)		4,36	4,34	4,35	4,33	4,38	4,35	4,36
Compliance Tier 2 (2021)	(1)		N	N	N	N	N	N	N
Compliance 23/18									
η_{sc}	(2)	%	-	-	-	-	-	-	-
SEER	(2)		-	-	-	-	-	-	-
Compliance Tier 2 (2021)	(2)		-	-	-	-	-	-	-
Compliance SEPR									
SEPR	(3)		-	-	-	-	-	-	-
Compliance Tier 2 (2021)	(3)		Y	Y	Y	Y	Y	Y	Y

Y = unit in compliance with Ecodesign at the indicated condition.

N = unit not in compliance with Ecodesign at the given condition: it can be installed only in non-EU countries.

- = value not necessary: conformity is already provided at the most restrictive condition (1).

(1) User-side heat exchanger water inlet/outlet temperature 12/7°C (low temperature application), with reference to regulation 2016/2281 and standard EN 14825.

(2) User-side heat exchanger water inlet/outlet temperature 23/18°C (medium temperature application), with reference to regulation 2016/2281 and standard EN 14825.

(3) User-side heat exchanger water inlet/outlet temperature 12/7°C, with reference to regulation 2016/2281 and norm EN 14825.

KAPPA REV SLN

			100.2	105.2	115.2	120.2	134.4	146.4	160.4
REGULATION 2016/2281									
Pdesign	(1)	kW	1045	1097	1166	1254	1407	1480	1567
Compliance 12/7									
η_{sc}	(1)	%	166,6	167	167,4	166,6	166,6	166,6	166,2
SEER	(1)		4,24	4,25	4,26	4,24	4,24	4,24	4,23
Compliance Tier 2 (2021)	(1)		N	N	N	N	N	N	N
Compliance 12/7 unit with EC fans									
η_{sc}	(1)	%	171,8	172,2	172,2	172,6	170,6	171,4	170,6
SEER	(1)		4,37	4,38	4,38	4,39	4,34	4,36	4,34
Compliance Tier 2 (2021)	(1)		N	N	N	N	N	N	N
Compliance 23/18									
η_{sc}	(2)	%	-	-	-	-	-	-	-
SEER	(2)		-	-	-	-	-	-	-
Compliance Tier 2 (2021)	(2)		-	-	-	-	-	-	-
Compliance SEPR									
SEPR	(3)		-	-	-	-	-	-	-
Compliance Tier 2 (2021)	(3)		Y	Y	Y	Y	Y	Y	Y

Y = unit in compliance with Ecodesign at the indicated condition.

KAPPA REV SLN /HP

			33.2	35.2	37.2	40.2	43.2	51.2
REGULATION 2013/813								
P _{design}	(4)	kW	306	343	364	385	360	385
Compliance	(4)		Y	Y	Y	Y	Y	Y
η _{sh}	(4)	%	1,302	1,29	1,274	1,258	1,258	1,258
SCOP	(4)		3,33	3,3	3,26	3,22	3,22	3,22

Y = unit in compliance with Ecodesign at the indicated condition.

(4) User-side heat exchanger water inlet/outlet temperature 30/35, Average climate profile, with reference to regulation 2013/813 and norm EN 14825.

KAPPA REV SLN /HP

			54.2	58.2	67.2	73.2	80.2	80.4	86.4
REGULATION 2016/2281									
P _{design}	(1)	kW	537	628	680	715	759	823	913
Compliance 12/7									
η _{sc}	(1)	%	162,2	161,8	161,4	161,4	161,4	162,2	162,2
SEER	(1)		4,13	4,12	4,11	4,11	4,11	4,13	4,13
Compliance Tier 2 (2021)	(1)		N	N	N	N	N	N	N
Compliance 12/7 unit with EC fans									
η _{sc}	(1)	%	167,4	167	166,6	166,6	166,6	167,4	167,4
SEER	(1)		4,26	4,25	4,24	4,24	4,24	4,26	4,26
Compliance Tier 2 (2021)	(1)		N	N	N	N	N	N	N

Y = unit in compliance with Ecodesign at the indicated condition.

N = unit not in compliance with Ecodesign at the given condition: it can be installed only in non-EU countries.

- = value not necessary: conformity is already provided at the most restrictive condition (1).

(1) User-side heat exchanger water inlet/outlet temperature 12/7°C (low temperature application), with reference to regulation 2016/2281 and standard EN 14825.

(2) User-side heat exchanger water inlet/outlet temperature 23/18°C (medium temperature application), with reference to regulation 2016/2281 and standard EN 14825.

(3) User-side heat exchanger water inlet/outlet temperature 12/7°C, with reference to regulation 2016/2281 and norm EN 14825.

KAPPA REV SLN /HP

			102.4	108.4	116.4	134.4	146.4	160.4
REGULATION 2016/2281								
P _{design}	(1)	kW	964	1075	1255	1359	1430	1517
Compliance 12/7								
η _{sc}	(1)	%	162,6	162,2	161,8	161,4	161,4	162,2
SEER	(1)		4,14	4,13	4,12	4,11	4,11	4,13
Compliance Tier 2 (2021)	(1)		N	N	N	N	N	N
Compliance 12/7 unit with EC fans								
η _{sc}	(1)	%	167,8	167,4	167	166,6	166,6	167,4
SEER	(1)		4,27	4,26	4,25	4,24	4,24	4,26
Compliance Tier 2 (2021)	(1)		N	N	N	N	N	N

Y = unit in compliance with Ecodesign at the indicated condition.

N = unit not in compliance with Ecodesign at the given condition: it can be installed only in non-EU countries.

- = value not necessary: conformity is already provided at the most restrictive condition (1).

(1) User-side heat exchanger water inlet/outlet temperature 12/7°C (low temperature application), with reference to regulation 2016/2281 and standard EN 14825.

(2) User-side heat exchanger water inlet/outlet temperature 23/18°C (medium temperature application), with reference to regulation 2016/2281 and standard EN 14825.

KAPPA REV (R513A)

			33.2	35.2	37.2	40.2	43.2	51.2	54.2
REGULATION 2016/2281									
Pdesign	(1)	kW	311,96	350,92	373,37	410,1	452,93	489,43	563,95
Compliance 12/7									
η _{sc}	(1)	%	-	-	-	-	-	-	-
SEER	(1)		-	-	-	-	-	-	-
Compliance Tier 2 (2021)	(1)		N	N	N	N	N	N	N
Compliance 12/7 unit with EC fans									
η _{sc}	(1)	%	-	-	-	-	-	-	-
SEER	(1)		-	-	-	-	-	-	-
Compliance Tier 2 (2021)	(1)		N	N	N	N	N	N	N
Compliance 23/18									
η _{sc}	(2)	%	171,4	181,8	176,6	166,6	166,2	169,4	168,6
SEER	(2)		4,36	4,62	4,49	4,24	4,23	4,31	4,29
Compliance Tier 2 (2021)	(2)		Y	Y	Y	N	N	N	N
Compliance SEPR									
SEPR	(3)		5,14	5,58	5,14	-	-	-	-
Compliance Tier 2 (2021)	(3)		Y	Y	Y	N	N	N	N

Y = unit in compliance with Ecodesign at the indicated condition.

			58.2	67.2	73.2	80.2	85.2	90.2	95.2
REGULATION 2016/2281									
Pdesign	(1)	kW	606,31	681,63	736,47	774,77	826,22	892,06	937,79
Compliance 12/7									
η _{sc}	(1)	%	-	-	-	-	-	-	-
SEER	(1)		-	-	-	-	-	-	-
Compliance Tier 2 (2021)	(1)		N	N	N	N	N	N	N
Compliance 12/7 unit with EC fans									
η _{sc}	(1)	%	-	-	-	-	-	-	-
SEER	(1)		-	-	-	-	-	-	-
Compliance Tier 2 (2021)	(1)		N	N	N	N	N	N	N
Compliance 23/18									
η _{sc}	(2)	%	166,2	166,2	167,4	171,4	172,6	168,6	171,4
SEER	(2)		4,23	4,23	4,26	4,36	4,39	4,29	4,36
Compliance Tier 2 (2021)	(2)		N	N	N	N	N	N	N
Compliance SEPR									
SEPR	(3)		-	-	-	-	-	-	-
Compliance Tier 2 (2021)	(3)		N	N	N	N	N	N	N

Y = unit in compliance with Ecodesign at the indicated condition.

N = unit not in compliance with Ecodesign at the given condition: it can be installed only in non-EU countries.

- = value not necessary: conformity is already provided at the most restrictive condition (1).

(1) User-side heat exchanger water inlet/outlet temperature 12/7°C (low temperature application), with reference to regulation 2016/2281 and standard EN 14825.

(2) User-side heat exchanger water inlet/outlet temperature 23/18°C (medium temperature application), with reference to regulation 2016/2281 and standard EN 14825.

(3) User-side heat exchanger water inlet/outlet temperature 12/7°C, with reference to regulation 2016/2281 and norm EN 14825.

KAPPA REV (R513A)

			100.2	105.2	115.2	120.2	130.2	140.3
REGULATION 2016/2281								
Pdesign	(1)	kW	980,25	1040,27	1111,44	1185,38	1274,33	1397,94
Compliance 12/7								
η _{sc}	(1)	%	-	-	-	-	-	-
SEER	(1)		-	-	-	-	-	-
Compliance Tier 2 (2021)	(1)		N	N	N	N	N	N
Compliance 12/7 unit with EC fans								
η _{sc}	(1)	%	-	-	-	-	-	-
SEER	(1)		-	-	-	-	-	-
Compliance Tier 2 (2021)	(1)		N	N	N	N	N	N
Compliance 23/18								
η _{sc}	(2)	%	171	174,2	184,2	185,8	191,8	166,2
SEER	(2)		4,35	4,43	4,68	4,72	4,87	4,87
Compliance Tier 2 (2021)	(2)		N	N	N	N	N	N
Compliance SEPR								
SEPR	(3)		-	-	-	-	-	-
Compliance Tier 2 (2021)	(3)		N	N	N	N	N	N

Y = unit in compliance with Ecodesign at the indicated condition.

			150.3	160.3	170.4	180.4	190.4	200.4
REGULATION 2016/2281								
Pdesign	(1)	kW	1469,27	1512,25	1652,82	1784,55	1876,1	1961,07
Compliance 12/7								
η _{sc}	(1)	%	-	-	-	-	-	-
SEER	(1)		-	-	-	-	-	-
Compliance Tier 2 (2021)	(1)		N	N	N	N	N	N
Compliance 12/7 unit with EC fans								
η _{sc}	(1)	%	-	-	-	-	-	-
SEER	(1)		-	-	-	-	-	-
Compliance Tier 2 (2021)	(1)		N	N	N	N	N	N
Compliance 23/18								
η _{sc}	(2)	%	171	169,8	173	169,4	172,2	171,4
SEER	(2)		4,23	4,35	4,32	4,4	4,31	4,38
Compliance Tier 2 (2021)	(2)		N	N	N	N	N	N
Compliance SEPR								
SEPR	(3)		-	-	-	-	-	-
Compliance Tier 2 (2021)	(3)		N	N	N	N	N	N

Y = unit in compliance with Ecodesign at the indicated condition.

N = unit not in compliance with Ecodesign at the given condition: it can be installed only in non-EU countries.

- = value not necessary: conformity is already provided at the most restrictive condition (1).

(1) User-side heat exchanger water inlet/outlet temperature 12/7°C (low temperature application), with reference to regulation 2016/2281 and standard EN 14825.

(2) User-side heat exchanger water inlet/outlet temperature 23/18°C (medium temperature application), with reference to regulation 2016/2281 and standard EN 14825.

(3) User-side heat exchanger water inlet/outlet temperature 12/7°C, with reference to regulation 2016/2281 and norm EN 14825.

KAPPA REV HE (R513A)

			33.2	35.2	37.2	40.2	43.2	51.2	54.2
REGULATION 2016/2281									
Pdesign	(1)	kW	335	384	404	461	510	521	579
Compliance 12/7									
η_{sc}	(1)	%	1,614	1,622	1,658	1,662	1,662	1,666	1,67
SEER	(1)		4,11	4,13	4,22	4,23	4,23	4,24	4,25
Compliance Tier 2 (2021)	(1)		Y	Y	N	N	N	N	N
Compliance 12/7 unit with EC fans									
η_{sc}	(1)	%	1,634	1,686	1,738	1,714	1,706	1,73	1,726
SEER	(1)		4,16	4,29	4,42	4,36	4,34	4,4	4,39
Compliance Tier 2 (2021)	(1)		Y	Y	N	N	N	N	N
Compliance 23/18									
η_{sc}	(2)	%	-	-	-	-	-	-	-
SEER	(2)		-	-	-	-	-	-	-
Compliance Tier 2 (2021)	(1)		-	-	-	-	-	-	-
Compliance SEPR									
SEPR	(3)		-	-	-	-	-	-	-
Compliance Tier 2 (2021)	(3)		Y	Y	Y	Y	Y	Y	Y

Y = unit in compliance with Ecodesign at the indicated condition.

			58.2	67.2	73.2	80.2	85.2	90.2	95.2
REGULATION 2016/2281									
Pdesign	(1)	kW	674	731	771	812	886	956	1011
Compliance 12/7									
η_{sc}	(1)	%	1,658	1,67	1,662	1,654	1,674	1,666	1,654
SEER	(1)		4,22	4,25	4,23	4,21	4,26	4,24	4,21
Compliance Tier 2 (2021)	(1)		N	N	N	N	N	N	N
Compliance 12/7 unit with EC fans									
η_{sc}	(1)	%	1,714	1,71	1,706	1,706	1,726	1,714	1,714
SEER	(1)		4,36	4,35	4,34	4,34	4,39	4,36	4,36
Compliance Tier 2 (2021)	(1)		N	N	N	N	N	N	N
Compliance 23/18									
η_{sc}	(2)	%	-	-	-	-	-	-	-
SEER	(2)		-	-	-	-	-	-	-
Compliance Tier 2 (2021)	(1)		-	-	-	-	-	-	-
Compliance SEPR									
SEPR	(3)		-	-	-	-	-	-	-
Compliance Tier 2 (2021)	(3)		Y	Y	Y	Y	Y	Y	Y

Y = unit in compliance with Ecodesign at the indicated condition.

N = unit not in compliance with Ecodesign at the given condition: it can be installed only in non-EU countries.

- = value not necessary: conformity is already provided at the most restrictive condition (1).

(1) User-side heat exchanger water inlet/outlet temperature 12/7°C (low temperature application), with reference to regulation 2016/2281 and standard EN 14825.

(2) User-side heat exchanger water inlet/outlet temperature 23/18°C (medium temperature application), with reference to regulation 2016/2281 and standard EN 14825.

(3) User-side heat exchanger water inlet/outlet temperature 12/7°C, with reference to regulation 2016/2281 and norm EN 14825.

KAPPA REV HE (R513A)

			100.2	105.2	115.2	120.2	134.4	146.4	160.4
REGULATION 2016/2281									
Pdesign	(1)	kW	1072	1146	1220	1319	1446	1521	1598
Compliance 12/7									
η_{sc}	(1)	%	1,666	1,674	1,67	1,666	1,67	1,662	1,662
SEER	(1)		4,24	4,26	4,25	4,24	4,25	4,23	4,23
Compliance Tier 2 (2021)	(1)		N	N	N	N	N	N	N
Compliance 12/7 unit with EC fans									
η_{sc}	(1)	%	1,718	1,726	1,718	1,726	1,71	1,71	1,706
SEER	(1)		4,37	4,39	4,37	4,39	4,35	4,35	4,34
Compliance Tier 2 (2021)	(1)		N	N	N	N	N	N	N
Compliance 23/18									
η_{sc}	(2)	%	-	-	-	-	-	-	-
SEER	(2)		-	-	-	-	-	-	-
Compliance Tier 2 (2021)	(1)		-	-	-	-	-	-	-
Compliance SEPR									
SEPR	(3)		-	-	-	-	-	-	-
Compliance Tier 2 (2021)	(3)		Y	Y	Y	Y	Y	Y	Y

Y = unit in compliance with Ecodesign at the indicated condition.

N = unit not in compliance with Ecodesign at the given condition: it can be installed only in non-EU countries.

- = value not necessary: conformity is already provided at the most restrictive condition (1).

- (1) User-side heat exchanger water inlet/outlet temperature 12/7°C (low temperature application), with reference to regulation 2016/2281 and standard EN 14825.
- (2) User-side heat exchanger water inlet/outlet temperature 23/18°C (medium temperature application), with reference to regulation 2016/2281 and standard EN 14825.
- (3) User-side heat exchanger water inlet/outlet temperature 12/7°C, with reference to regulation 2016/2281 and norm EN 14825.

KAPPA REV SLN (R513A)

			33.2	35.2	37.2	40.2	43.2	51.2	54.2
REGULATION 2016/2281									
Pdesign	(1)	kW	329	372	395	456	498	513	566
Compliance 12/7									
η_{sc}	(1)	%	1,61	1,614	1,63	1,654	1,658	1,658	1,662
SEER	(1)		4,1	4,11	4,15	4,21	4,22	4,22	4,23
Compliance Tier 2 (2021)	(1)		Y	Y	Y	N	N	N	N
Compliance 12/7 unit with EC fans									
η_{sc}	(1)	%	1,63	1,67	1,666	1,702	1,698	1,71	1,71
SEER	(1)		4,15	4,25	4,24	4,33	4,32	4,35	4,35
Compliance Tier 2 (2021)	(1)		Y	Y	Y	N	N	N	N
Compliance 23/18									
η_{sc}	(2)	%	-	-	-	-	-	-	-
SEER	(2)		-	-	-	-	-	-	-
Compliance Tier 2 (2021)	(1)		-	-	-	-	-	-	-
Compliance SEPR									
SEPR	(3)		-	-	-	-	-	-	-
Compliance Tier 2 (2021)	(3)		Y	Y	Y	Y	Y	Y	Y

Y = unit in compliance with Ecodesign at the indicated condition.

			58.2	67.2	73.2	80.2	85.2	90.2	95.2
REGULATION 2016/2281									
Pdesign	(1)	kW	669	730	757	799	881	942	1010
Compliance 12/7									
η_{sc}	(1)	%	1,654	1,658	1,654	1,654	1,666	1,658	1,65
SEER	(1)		4,21	4,22	4,21	4,21	4,24	4,22	4,2
Compliance Tier 2 (2021)	(1)		N	N	N	N	N	N	N
Compliance 12/7 unit with EC fans									
η_{sc}	(1)	%	1,706	1,694	1,698	1,69	1,71	1,706	1,706
SEER	(1)		4,34	4,31	4,32	4,3	4,35	4,34	4,34
Compliance Tier 2 (2021)	(1)		N	N	N	N	N	N	N
Compliance 23/18									
η_{sc}	(2)	%	-	-	-	-	-	-	-
SEER	(2)		-	-	-	-	-	-	-
Compliance Tier 2 (2021)	(1)		-	-	-	-	-	-	-
Compliance SEPR									
SEPR	(3)		-	-	-	-	-	-	-
Compliance Tier 2 (2021)	(3)		Y	Y	Y	Y	Y	Y	Y

Y = unit in compliance with Ecodesign at the indicated condition.

N = unit not in compliance with Ecodesign at the given condition: it can be installed only in non-EU countries.

- = value not necessary: conformity is already provided at the most restrictive condition (1).

- (1) User-side heat exchanger water inlet/outlet temperature 12/7°C (low temperature application), with reference to regulation 2016/2281 and standard EN 14825.
- (2) User-side heat exchanger water inlet/outlet temperature 23/18°C (medium temperature application), with reference to regulation 2016/2281 and standard EN 14825.
- (3) User-side heat exchanger water inlet/outlet temperature 12/7°C, with reference to regulation 2016/2281 and norm EN 14825.

KAPPA REV SLN (R513A)

			100.2	105.2	115.2	120.2	134.4	146.4	160.4
REGULATION 2016/2281									
Pdesign	(1)	kW	1076	1125	1190	1285	1446	1521	1603
Compliance 12/7									
η_{sc}	(1)	%	1,658	1,666	1,662	1,658	1,65	1,65	1,654
SEER	(1)		4,22	4,24	4,23	4,22	4,2	4,2	4,21
Compliance Tier 2 (2021)	(1)		N	N	N	N	N	N	N
Compliance 12/7 unit with EC fans									
η_{sc}	(1)	%	1,71	1,718	1,71	1,718	1,69	1,702	1,698
SEER	(1)		4,35	4,37	4,35	4,37	4,3	4,33	4,32
Compliance Tier 2 (2021)	(1)		N	N	N	N	N	N	N
Compliance 23/18									
η_{sc}	(2)	%	-	-	-	-	-	-	-
SEER	(2)		-	-	-	-	-	-	-
Compliance Tier 2 (2021)	(1)		-	-	-	-	-	-	-
Compliance SEPR									
SEPR	(3)		-	-	-	-	-	-	-
Compliance Tier 2 (2021)	(3)		Y	Y	Y	Y	Y	Y	Y

Y = unit in compliance with Ecodesign at the indicated condition.

N = unit not in compliance with Ecodesign at the given condition: it can be installed only in non-EU countries.

- = value not necessary: conformity is already provided at the most restrictive condition (1).

- (1) User-side heat exchanger water inlet/outlet temperature 12/7°C (low temperature application), with reference to regulation 2016/2281 and standard EN 14825.
- (2) User-side heat exchanger water inlet/outlet temperature 23/18°C (medium temperature application), with reference to regulation 2016/2281 and standard EN 14825.
- (3) User-side heat exchanger water inlet/outlet temperature 12/7°C, with reference to regulation 2016/2281 and norm EN 14825.

ELECTRICAL SPECIFICATIONS

KAPPA REV

			33.2	35.2	37.2	40.2	43.2	51.2	54.2	58.2
General electrical specifications										
Max. absorbed power (FLI)	(1)	kW	140,7	150,6	170,3	189,2	208,0	221,9	251,2	284,6
Max. absorbed current (FLA)	(1)	A	235,5	252,8	280,0	313,6	347,2	371,9	420,9	473,6
Nominal current (Inom)	(2)	A	181	195	211	235	260	280	317	358
cosφ standard unit	(2)		0,83	0,83	0,86	0,85	0,84	0,83	0,83	0,85
Nominal current with power factor correction (Inom)	(2)	A	156	170	187	208	227,5	244	274	317
cosφ unit with power factor correction	(2)		0,96	0,95	0,97	0,96	0,96	0,95	0,96	0,96
Maximum inrush current (MIC)	(3)	A	311	329	379	385	419	474	518	676
Power supply			400V / 3ph / 50Hz							
Power supply for auxiliary circuits			230V-24V / 1ph / 50Hz							
Suggested line section	(5)	mm²	3x150 + 1x95	400V / 3ph / 50Hz	400V / 3ph / 50Hz	400V / 3ph / 50Hz	400V / 3ph / 50Hz	400V / 3ph / 50Hz	400V / 3ph / 50Hz	400V / 3ph / 50Hz
Suggested line protection	(6)		NH2gG 315A	230V-24V / 1ph / 50Hz	230V-24V / 1ph / 50Hz	230V-24V / 1ph / 50Hz	230V-24V / 1ph / 50Hz	230V-24V / 1ph / 50Hz	230V-24V / 1ph / 50Hz	230V-24V / 1ph / 50Hz
Electrical specifications for fans										
Rated power of standard fan		n° x kW	5 x 2,00	5 x 1,45	6 x 1,45	6 x 1,45	6 x 1,45	6 x 1,45	7 x 1,45	8 x 1,45
Rated current of standard fan		n° x A	5 x 4,30	5 x 3,40	6 x 3,40	6 x 3,40	6 x 3,40	6 x 3,40	7 x 3,40	8 x 3,40
Rated power of EC fan		n° x kW	5 x 1,85	5 x 1,25	6 x 1,25	6 x 1,25	6 x 1,25	6 x 1,25	7 x 1,25	8 x 1,25
Rated current of EC fan		n° x A	5 x 2,85	5 x 1,90	6 x 1,90	6 x 1,90	6 x 1,90	6 x 1,90	7 x 1,90	8 x 1,90
Rated power of oversize EC fans		n° x kW	5 x 2,98	5 x 2,90	6 x 2,90	6 x 2,90	6 x 2,90	6 x 2,90	7 x 2,90	8 x 2,90
Rated current of oversize EC fans		n° x A	5 x 4,50	5 x 4,40	6 x 4,40	6 x 4,40	6 x 4,40	6 x 4,40	7 x 4,40	8 x 4,40
General electrical specifications										
			67.2	73.2	80.2	85.2	90.2	95.2	100.2	105.2
General electrical specifications										
Max. absorbed power (FLI)	(1)	kW	302,5	321,2	339,9	366,3	392,8	418,7	444,6	474,0
Max. absorbed current (FLA)	(1)	A	502,0	529,4	556,8	604,8	652,8	695,2	737,6	784,0
Nominal current (Inom)	(2)	A	383	417	451	474	498	529	560	599
cosφ standard unit	(2)		0,86	0,87	0,88	0,86	0,85	0,86	0,86	0,86
Nominal current with power factor correction (Inom)	(2)	A	340	374	409	420	441	474	507	542
cosφ unit with power factor correction	(2)		0,97	0,97	0,97	0,97	0,96	0,96	0,95	0,95
Maximum inrush current (MIC)	(3)	A	704	736	764	885	933	1.000	1.043	1.201
Power supply			400V / 3ph / 50Hz							
Power supply for auxiliary circuits			230V-24V / 1ph / 50Hz							
Suggested line section	(5)	mm²	400V / 3ph / 50Hz	400V / 3ph / 50Hz	400V / 3ph / 50Hz	400V / 3ph / 50Hz	400V / 3ph / 50Hz	400V / 3ph / 50Hz	400V / 3ph / 50Hz	400V / 3ph / 50Hz
Suggested line protection	(6)		230V-24V / 1ph / 50Hz	230V-24V / 1ph / 50Hz	230V-24V / 1ph / 50Hz	230V-24V / 1ph / 50Hz	230V-24V / 1ph / 50Hz	230V-24V / 1ph / 50Hz	230V-24V / 1ph / 50Hz	230V-24V / 1ph / 50Hz
Electrical specifications for fans										
Rated power of standard fan		n° x kW	9 x 1,45	10 x 1,45	11 x 1,45	12 x 1,45	12 x 1,45	12 x 1,45	13 x 1,45	14 x 1,45
Rated current of standard fan		n° x A	9 x 3,40	10 x 3,40	11 x 3,40	12 x 3,40	12 x 3,40	12 x 3,40	13 x 3,40	14 x 3,40
Rated power of EC fan		n° x kW	9 x 1,25	10 x 1,25	11 x 1,25	12 x 1,25	12 x 1,25	12 x 1,25	13 x 1,25	14 x 1,25
Rated current of EC fan		n° x A	9 x 1,90	10 x 1,90	11 x 1,90	12 x 1,90	12 x 1,90	12 x 1,90	13 x 1,90	14 x 1,90
Rated power of oversize EC fans		n° x kW	9 x 2,90	10 x 2,90	11 x 2,90	12 x 2,90	12 x 2,90	12 x 2,90	13 x 2,90	14 x 2,90
Rated current of oversize EC fans		n° x A	9 x 4,40	10 x 4,40	11 x 4,40	12 x 4,40	12 x 4,40	12 x 4,40	13 x 4,40	14 x 4,40

(1) Data regarding the unit without accessories working in maximum power absorption conditions

(2) Datum related to the unit without accessories working in standard conditions (A35°C; W12/7°C)

(3) Maximum effective RMS value of the current when the last compressor starts (FLA of the entire unit - FLA of the largest compressor + LRA of the largest compressor)

(5) These values are determined for cables with operating temperature of 40°C, EPR insulation and a line with a maximum length of 50m. The line section must be determined by a qualified technician based on the protection devices, the length of the line, the type of cable used and the type of installation.

(6) The correct line protection part must be determined by a qualified technician based on the length of the line, the type of cable used and the type of installation.

KAPPA REV

			115.2	120.2	130.2	140.3	150.3	160.3
General electrical specifications								
Max. absorbed power (FLI)	(1)	kW	503,4	543,1	578,3	641,1	667,1	724,1
Max. absorbed current (FLA)	(1)	A	830,4	907,2	907,2	1.064,0	1.106,4	1.195,8
Nominal current (Inom)	(2)	A	638	697	697	809	840	879
cosφ standard unit	(2)		0,86	0,85	0,85	0,86	0,86	0,86
Nominal current with power factor correction (Inom)	(2)	A	577	623	623	732	760	796
cosφ unit with power factor correction	(2)		0,95	0,95	0,95	0,95	0,95	0,95
Maximum inrush current (MIC)	(3)	A	1.247	1.401	1.401	1.369	1.411	1.613
Power supply			400V / 3ph / 50Hz					
Power supply for auxiliary circuits			230V-24V / 1ph / 50Hz					
Suggested line section	(5)	mm²	400V / 3ph / 50Hz	400V / 3ph / 50Hz	400V / 3ph / 50Hz	400V / 3ph / 50Hz	400V / 3ph / 50Hz	400V / 3ph / 50Hz
Suggested line protection	(6)		230V-24V / 1ph / 50Hz	230V-24V / 1ph / 50Hz	230V-24V / 1ph / 50Hz	230V-24V / 1ph / 50Hz	230V-24V / 1ph / 50Hz	230V-24V / 1ph / 50Hz
Electrical specifications for fans								
Rated power of standard fan		n° x kW	15 x 1,45	16 x 1,45	18 x 1,45	18 x 1,45	20 x 1,45	21 x 1,45
Rated current of standard fan		n° x A	15 x 3,40	16 x 3,40	18 x 3,40	18 x 3,40	20 x 3,40	21 x 3,40
Rated power of EC fan		n° x kW	15 x 1,25	16 x 1,25	18 x 1,25	18 x 1,25	20 x 1,25	21 x 1,25
Rated current of EC fan		n° x A	15 x 1,90	16 x 1,90	18 x 1,90	18 x 1,90	20 x 1,90	21 x 1,90
Rated power of oversize EC fans		n° x kW	15 x 2,90	16 x 2,90	18 x 2,90	18 x 2,90	20 x 2,90	21 x 2,90
Rated current of oversize EC fans		n° x A	15 x 4,40	16 x 4,40	18 x 4,40	18 x 4,40	20 x 4,40	21 x 4,40
			160.4	170.4	180.4	190.4	200.4	
General electrical specifications								
Max. absorbed power (FLI)	(1)	kW	693	746	799	852	905	
Max. absorbed current (FLA)	(1)	A	1.135	1.231	1.327	1.414	1.500	
Nominal current (Inom)	(2)	A	902	948	996	1.058	1.120	
cosφ standard unit	(2)							
Nominal current with power factor correction (Inom)	(2)	A						
cosφ unit with power factor correction	(2)							
Maximum inrush current (MIC)	(3)	A	1.342	1.511	1.607	1.719	1.805	
Power supply			400V / 3ph / 50Hz					
Power supply for auxiliary circuits			230V-24V / 1ph / 50Hz					
Suggested line section	(5)	mm²	400V / 3ph / 50Hz	400V / 3ph / 50Hz	400V / 3ph / 50Hz	400V / 3ph / 50Hz	400V / 3ph / 50Hz	400V / 3ph / 50Hz
Suggested line protection	(6)		230V-24V / 1ph / 50Hz	230V-24V / 1ph / 50Hz	230V-24V / 1ph / 50Hz	230V-24V / 1ph / 50Hz	230V-24V / 1ph / 50Hz	230V-24V / 1ph / 50Hz
Electrical specifications for fans								
Rated power of standard fan		n° x kW	22 x 1,45	24 x 1,45	24 x 1,45	26 x 1,45	28 x 1,45	
Rated current of standard fan		n° x A	22 x 3,40	24 x 3,40	24 x 3,40	26 x 3,40	28 x 3,40	
Rated power of EC fan		n° x kW	22 x 1,25	24 x 1,25	24 x 1,25	26 x 1,25	28 x 1,25	
Rated current of EC fan		n° x A	22 x 1,90	24 x 1,90	24 x 1,90	26 x 1,90	28 x 1,90	
Rated power of oversize EC fans		n° x kW	22 x 2,90	24 x 2,90	24 x 2,90	26 x 2,90	28 x 2,90	
Rated current of oversize EC fans		n° x A	22 x 4,40	24 x 4,40	24 x 4,40	26 x 4,40	28 x 4,40	

- (1) Data regarding the unit without accessories working in maximum power absorption conditions
- (2) Datum related to the unit without accessories working in standard conditions (A35°C; W12/7°C)
- (3) Maximum effective RMS value of the current when the last compressor starts (FLA of the entire unit - FLA of the largest compressor + LRA of the largest compressor)
- (5) These values are determined for cables with operating temperature of 40°C, EPR insulation and a line with a maximum length of 50m. The line section must be determined by a qualified technician based on the protection devices, the length of the line, the type of cable used and the type of installation.
- (6) The correct line protection part must be determined by a qualified technician based on the length of the line, the type of cable used and the type of installation.

KAPPA REV HE - KAPPA REV SLN

			33.2	35.2	37.2	40.2	43.2	51.2	54.2	58.2	67.2
General electrical specifications											
Max. absorbed power (FLI)	(1)	kW	141,7	161,9	173,2	192,1	210,9	224,8	255,6	288,9	305,4
Max. absorbed current (FLA)	(1)	A	238,9	269,8	286,8	320,4	354,0	378,7	431,1	483,8	508,8
Nominal current (Inom)	(2)	A	185	199	219	243	268	288	329	370	391
cosφ standard unit	(2)		0,83	0,83	0,86	0,85	0,84	0,83	0,83	0,85	0,86
Nominal current with power factor correction (Inom)	(2)	A	159	173	194	215	234	251	284	327	346
cosφ unit with power factor correction	(2)		0,96	0,95	0,97	0,96	0,96	0,95	0,96	0,96	0,97
Maximum inrush current (MIC)	(3)	A	315	369	386	392	426	481	528	686	711
Power supply	400V / 3ph / 50Hz										
Power supply for auxiliary circuits	230V-24V / 1ph / 50Hz										
Suggested line section	(5)	mm²	3x150 + 1x95	3x150 + 1x95	2x(3x70) + 1x70	2x(3x70) + 1x70	2x(3x120) + 1x120	2x(3x120) + 1x120	2x(3x120) + 1x120	2x(3x150) + 1x150	2x(3x150) + 1x150
Suggested line protection	(6)		NH2gG 315A	NH2gG 315A	NH2gG 400A	NH2gG 400A	NH3gG 500A	NH3gG 500A	NH3gG 500A	NH3gG 630A	NH3gG 630A
Electrical specifications for fans											
Rated power of standard fan		n° x kW	6 x 1,45	7 x 1,45	8 x 1,45	8 x 1,45	8 x 1,45	9 x 1,45	11 x 1,45	12 x 1,45	12 x 1,45
Rated current of standard fan		n° x A	6 x 3,40	7 x 3,40	8 x 3,40	8 x 3,40	8 x 3,40	9 x 3,40	11 x 3,40	12 x 3,40	12 x 3,40
Rated power of EC fan		n° x kW	6 x 1,25	7 x 1,25	8 x 1,25	8 x 1,25	8 x 1,25	9 x 1,25	11 x 1,25	12 x 1,25	12 x 1,25
Rated current of EC fan		n° x A	6 x 1,90	7 x 1,90	8 x 1,90	8 x 1,90	8 x 1,90	9 x 1,90	11 x 1,90	12 x 1,90	12 x 1,90
Rated power of oversize EC fans		n° x kW	6 x 2,90	7 x 2,90	8 x 2,90	8 x 2,90	8 x 2,90	9 x 2,90	11 x 2,90	12 x 2,90	12 x 2,90
Rated current of oversize EC fans		n° x A	6 x 4,40	7 x 4,40	8 x 4,40	8 x 4,40	8 x 4,40	9 x 4,40	11 x 4,40	12 x 4,40	12 x 4,40
			73.2	80.2	85.2	90.2	95.2	100.2	105.2	115.2	120.2
General electrical specifications											
Max. absorbed power (FLI)	(1)	kW	324,1	342,8	370,7	398,6	424,5	450,4	479,8	510,7	548,9
Max. absorbed current (FLA)	(1)	A	536,2	563,6	615,0	666,4	708,8	751,2	797,6	847,4	920,8
Nominal current (Inom)	(2)	A	425	459	486	515	546	577	616	659	714
cosφ standard unit	(2)		0,87	0,88	0,86	0,85	0,86	0,86	0,86	0,86	0,85
Nominal current with power factor correction (Inom)	(2)	A	381	416	430	455	489	522	557	596	638
cosφ unit with power factor correction	(2)		0,97	0,97	0,97	0,96	0,96	0,95	0,95	0,95	0,95
Maximum inrush current (MIC)	(3)	A	743	771	895	946	1.014	1.056	1.215	1.264	1.415
Power supply	400V / 3ph / 50Hz										
Power supply for auxiliary circuits	230V-24V / 1ph / 50Hz										
Suggested line section	(5)	mm²	2x(3x150) + 1x150	2x(3x240) + 1x240	2x(3x240) + 1x240	2x(3x240) + 1x240	4x(3x120) + 2x120	4x(3x150) + 2x150	4x(3x150) + 2x150	4x(3x150) + 2x150	4x(3x150) + 2x150
Suggested line protection	(6)		NH3gG 630A	NH4gG 800A	NH4gG 800A	NH4gG 800A	NH4gG 1000A	NH4gG 1250A	NH4gG 1250A	NH4gG 1250A	NH4gG 1250A
Electrical specifications for fans											
Rated power of standard fan		n° x kW	13 x 1,45	14 x 1,45	15 x 1,45	16 x 1,45	17 x 1,45	18 x 1,45	19 x 1,45	21 x 1,45	22 x 1,45
Rated current of standard fan		n° x A	13 x 3,40	14 x 3,40	15 x 3,40	16 x 3,40	17 x 3,40	18 x 3,40	19 x 3,40	21 x 3,40	22 x 3,40
Rated power of EC fan		n° x kW	13 x 1,25	14 x 1,25	15 x 1,25	16 x 1,25	17 x 1,25	18 x 1,25	19 x 1,25	21 x 1,25	22 x 1,25
Rated current of EC fan		n° x A	13 x 1,90	14 x 1,90	15 x 1,90	16 x 1,90	17 x 1,90	18 x 1,90	19 x 1,90	21 x 1,90	22 x 1,90
Rated power of oversize EC fans		n° x kW	13 x 2,90	14 x 2,90	15 x 2,90	16 x 2,90	17 x 2,90	18 x 2,90	19 x 2,90	21 x 2,90	22 x 2,90
Rated current of oversize EC fans		n° x A	13 x 4,40	14 x 4,40	15 x 4,40	16 x 4,40	17 x 4,40	18 x 4,40	19 x 4,40	21 x 4,40	22 x 4,40

(1) Data regarding the unit without accessories working in maximum power absorption conditions

(2) Datum related to the unit without accessories working in standard conditions (A35°C; W12/7°C)

(3) Maximum effective RMS value of the current when the last compressor starts (FLA of the entire unit - FLA of the largest compressor + LRA of the largest compressor)

(5) These values are determined for cables with operating temperature of 40°C, EPR insulation and a line with a maximum length of 50m. The line section must be determined by a qualified technician based on the protection devices, the length of the line, the type of cable used and the type of installation.

(6) The correct line protection part must be determined by a qualified technician based on the length of the line, the type of cable used and the type of installation.

KAPPA REV HE - KAPPA REV SLN

			134.4	146.4	160.4
General electrical specifications					
Max. absorbed power (FLI)	(1)	kW	610,8	648,2	685,6
Max. absorbed current (FLA)	(1)	A	1.017,6	1.072,4	1.127,2
Nominal current (Inom)	(2)	A	782	850	918
cosφ standard unit	(2)				
Nominal current with power factor correction (Inom)	(2)	A			
cosφ unit with power factor correction	(2)				
Maximum inrush current (MIC)	(3)	A	1.220	1.279	1.334
Power supply			400V / 3ph / 50Hz		
Power supply for auxiliary circuits			230V-24V / 1ph / 50Hz		
Suggested line section	(5)	mm ²			
Suggested line protection	(6)				
Electrical specifications for fans					
Rated power of standard fan		n° x kW	24 x 1,45	26 x 1,45	28 x 1,45
Rated current of standard fan		n° x A	24 x 3,40	26 x 3,40	28 x 3,40
Rated power of EC fan		n° x kW	24 x 1,25	26 x 1,25	28 x 1,25
Rated current of EC fan		n° x A	24 x 1,90	26 x 1,90	28 x 1,90
Rated power of oversize EC fans		n° x kW	24 x 2,90	26 x 2,90	28 x 2,90
Rated current of oversize EC fans		n° x A	24 x 4,40	26 x 4,40	28 x 4,40

- (1) Data regarding the unit without accessories working in maximum power absorption conditions
- (2) Datum related to the unit without accessories working in standard conditions (A35°C; W12/7°C)
- (3) Maximum effective RMS value of the current when the last compressor starts (FLA of the entire unit - FLA of the largest compressor + LRA of the largest compressor)
- (5) These values are determined for cables with operating temperature of 40°C, EPR insulation and a line with a maximum length of 50m. The line section must be determined by a qualified technician based on the protection devices, the length of the line, the type of cable used and the type of installation.
- (6) The correct line protection part must be determined by a qualified technician based on the length of the line, the type of cable used and the type of installation.

KAPPA REV (R513A)

			33.2	35.2	37.2	40.2	43.2	51.2	54.2
General electrical specifications									
Max. absorbed power (FLI)	(1)	kW	146,0	156,3	176,8	196,4	216,0	230,3	260,8
Max. absorbed current (FLA)	(1)	A	244,2	262,1	290,4	325,3	360,3	385,8	436,6
Nominal current (Inom)	(2)	A	185,5	200	215,5	239,2	266	286,5	323
cosφ standard unit	(2)		0,83	0,83	0,86	0,85	0,84	0,83	0,83
Nominal current with power factor correction (Inom)	(2)	A	160	174	191	211	232	250	279
cosφ unit with power factor correction	(2)		0,96	0,95	0,97	0,96	0,96	0,95	0,96
Maximum inrush current (MIC)	(3)	A	323	341	394	400	435	492	537
Power supply			400V / 3ph / 50Hz						
Power supply for auxiliary circuits			230V-24V / 1ph / 50Hz						
Suggested line section	(5)	mm²	3x150 + 1x95	3x150 + 1x95	2x(3x70) + 1x70	2x(3x70) + 1x70	2x(3x120) + 1x120	2x(3x120) + 1x120	2x(3x120) + 1x120
Suggested line protection	(6)		NH2gG 315A	NH2gG 315A	NH2gG 400A	NH2gG 400A	NH3gG 500A	NH3gG 500A	NH3gG 500A
Electrical specifications for fans									
Rated power of standard fan		n° x kW	5 x 1,45	6 x 1,45	6 x 1,45	6 x 1,45	6 x 1,45	7 x 1,45	8 x 1,45
Rated current of standard fan		n° x A	5 x 3,40	6 x 3,40	6 x 3,40	6 x 3,40	6 x 3,40	7 x 3,40	8 x 3,40
Rated power of EC fan		n° x kW	5 x 1,25	6 x 1,25	6 x 1,25	6 x 1,25	6 x 1,25	7 x 1,25	8 x 1,25
Rated current of EC fan		n° x A	5 x 1,90	6 x 1,90	6 x 1,90	6 x 1,90	6 x 1,90	7 x 1,90	8 x 1,90
Rated power of oversize EC fans		n° x kW	5 x 2,90	6 x 2,90	6 x 2,90	6 x 2,90	6 x 2,90	7 x 2,90	8 x 2,90
Rated current of oversize EC fans		n° x A	5 x 4,40	6 x 4,40	6 x 4,40	6 x 4,40	6 x 4,40	7 x 4,40	8 x 4,40

- (1) Data regarding the unit without accessories working in maximum power absorption conditions
- (2) Datum related to the unit without accessories working in standard conditions (A35°C; W12/7°C)
- (3) Maximum effective RMS value of the current when the last compressor starts (FLA of the entire unit - FLA of the largest compressor + LRA of the largest compressor)
- (5) These values are determined for cables with operating temperature of 40°C, EPR insulation and a line with a maximum length of 50m. The line section must be determined by a qualified technician based on the protection devices, the length of the line, the type of cable used and the type of installation.
- (6) The correct line protection part must be determined by a qualified technician based on the length of the line, the type of cable used and the type of installation.

KAPPA REV (R513A)

			58.2	67.2	73.2	80.2	85.2	90.2	95.2
General electrical specifications									
Max. absorbed power (FLI)	(1)	kW	295,5	314,0	333,4	352,8	380,3	407,8	434,7
Max. absorbed current (FLA)	(1)	A	491,3	520,7	549,1	577,4	627,4	677,3	721,2
Nominal current (Inom)	(2)	A	364,5	389	423,5	457	480,5	504	535,5
cosφ standard unit	(2)		0,85	0,86	0,87	0,88	0,86	0,85	0,86
Nominal current with power factor correction (Inom)	(2)	A	322	344	379	414	426	446	479
cosφ unit with power factor correction	(2)		0,96	0,97	0,97	0,97	0,97	0,96	0,96
Maximum inrush current (MIC)	(3)	A	701	731	764	793	919	969	1.038
Power supply			400V / 3ph / 50Hz	400V / 3ph / 50Hz					
Power supply for auxiliary circuits			230V-24V / 1ph / 50Hz	230V-24V / 1ph / 50Hz					
Suggested line section	(5)	mm²	2x(3x150) + 1x150	2x(3x150) + 1x150	2x(3x150) + 1x150	2x(3x240) + 1x240	2x(3x240) + 1x240	2x(3x240) + 1x240	4x(3x120) + 2x120
Suggested line protection	(6)		NH3gG 630A	NH3gG 630A	NH3gG 630A	NH4gG 800A	NH4gG 800A	NH4gG 800A	NH4gG 1000A
Electrical specifications for fans									
Rated power of standard fan		n° x kW	9 x 1,45	10 x 1,45	11 x 1,45	12 x 1,45	12 x 1,45	12 x 1,45	13 x 1,45
Rated current of standard fan		n° x A	9 x 3,40	10 x 3,40	11 x 3,40	12 x 3,40	12 x 3,40	12 x 3,40	13 x 3,40
Rated power of EC fan		n° x kW	9 x 1,25	10 x 1,25	11 x 1,25	12 x 1,25	12 x 1,25	12 x 1,25	13 x 1,25
Rated current of EC fan		n° x A	9 x 1,90	10 x 1,90	11 x 1,90	12 x 1,90	12 x 1,90	12 x 1,90	13 x 1,90
Rated power of oversize EC fans		n° x kW	9 x 2,90	10 x 2,90	11 x 2,90	12 x 2,90	12 x 2,90	12 x 2,90	13 x 2,90
Rated current of oversize EC fans		n° x A	9 x 4,40	10 x 4,40	11 x 4,40	12 x 4,40	12 x 4,40	12 x 4,40	13 x 4,40

- (1) Data regarding the unit without accessories working in maximum power absorption conditions
- (2) Datum related to the unit without accessories working in standard conditions (A35°C; W12/7°C)
- (3) Maximum effective RMS value of the current when the last compressor starts (FLA of the entire unit - FLA of the largest compressor + LRA of the largest compressor)
- (5) These values are determined for cables with operating temperature of 40°C, EPR insulation and a line with a maximum length of 50m. The line section must be determined by a qualified technician based on the protection devices, the length of the line, the type of cable used and the type of installation.
- (6) The correct line protection part must be determined by a qualified technician based on the length of the line, the type of cable used and the type of installation.

KAPPA REV (R513A)

			100.2	105.2	115.2	120.2	130.2	140.3	150.3
General electrical specifications									
Max. absorbed power (FLI)	(1)	kW	461,6	492,1	522,7	563,8	600,4	665,6	692,5
Max. absorbed current (FLA)	(1)	A	765,2	813,3	861,4	941,0	941,0	1.103,8	1.147,8
Nominal current (Inom)	(2)	A	566	605,5	644	703,5	703	815,5	846
cosφ standard unit	(2)		0,86	0,86	0,86	0,85	0,85	0,86	0,86
Nominal current with power factor correction (Inom)	(2)	A	512	548	582	629	629	738	765
cosφ unit with power factor correction	(2)		0,95	0,95	0,95	0,95	0,95	0,95	0,95
Maximum inrush current (MIC)	(3)	A	1.082	1.247	1.295	1.455	1.455	1.421	1.465
Power supply			400V / 3ph / 50Hz			400V / 3ph / 50Hz			
Power supply for auxiliary circuits			230V-24V / 1ph / 50Hz			230V-24V / 1ph / 50Hz			
Suggested line section	(5)	mm²	4x(3x150) + 2x150	4x(3x150) + 2x150	4x(3x150) + 2x150	4x(3x150) + 2x150	4x(3x150) + 2x150	4x(3x240) + 2x240	4x(3x240) + 2x240
Suggested line protection	(6)		NH4gG 1250A	NH4gG 1250A	NH4gG 1250A	NH4gG 1250A	NH4gG 1250A	NH4gG 1600A	NH4gG 1600A
Electrical specifications for fans									
Rated power of standard fan		n° x kW	14 x 1,45	15 x 1,45	16 x 1,45	18 x 1,45	18 x 1,45	20 x 1,45	21 x 1,45
Rated current of standard fan		n° x A	14 x 3,40	15 x 3,40	16 x 3,40	18 x 3,40	18 x 3,40	20 x 3,40	21 x 3,40
Rated power of EC fan		n° x kW	14 x 1,25	15 x 1,25	16 x 1,25	18 x 1,25	18 x 1,25	20 x 1,25	21 x 1,25
Rated current of EC fan		n° x A	14 x 1,90	15 x 1,90	16 x 1,90	18 x 1,90	18 x 1,90	20 x 1,90	21 x 1,90
Rated power of oversize EC fans		n° x kW	14 x 2,90	15 x 2,90	16 x 2,90	18 x 2,90	18 x 2,90	20 x 2,90	21 x 2,90
Rated current of oversize EC fans		n° x A	14 x 4,40	15 x 4,40	16 x 4,40	18 x 4,40	18 x 4,40	20 x 4,40	21 x 4,40
General electrical specifications									
			160.3	170.4	180.4	190.4	200.4		
General electrical specifications									
Max. absorbed power (FLI)	(1)	kW	751,8	760,6	815,6	869,4	923,2		
Max. absorbed current (FLA)	(1)	A	1.240,6	1.254,7	1.354,6	1.442,5	1.530,4		
Nominal current (Inom)	(2)	A	885,5	967,5	1014,5	1077,5	1138,5		
cosφ standard unit	(2)		0,86						
Nominal current with power factor correction (Inom)	(2)	A	801						
cosφ unit with power factor correction	(2)		0,95						
Maximum inrush current (MIC)	(3)	A	1.674	1.546	1.646	1.760	1.848		
Power supply			400V / 3ph / 50Hz						
Power supply for auxiliary circuits			230V-24V / 1ph / 50Hz						
Suggested line section	(5)	mm²	4x(3x240) + 2x240						
Suggested line protection	(6)		NH4gG 1600A						
Electrical specifications for fans									
Rated power of standard fan		n° x kW	22 x 1,45	24 x 1,45	24 x 1,45	26 x 1,45	28 x 1,45		
Rated current of standard fan		n° x A	22 x 3,40	24 x 3,40	24 x 3,40	26 x 3,40	28 x 3,40		
Rated power of EC fan		n° x kW	22 x 1,25	24 x 1,25	24 x 1,25	26 x 1,25	28 x 1,25		
Rated current of EC fan		n° x A	22 x 1,90	24 x 1,90	24 x 1,90	26 x 1,90	28 x 1,90		
Rated power of oversize EC fans		n° x kW	22 x 2,90	24 x 2,90	24 x 2,90	26 x 2,90	28 x 2,90		
Rated current of oversize EC fans		n° x A	22 x 4,40	24 x 4,40	24 x 4,40	26 x 4,40	28 x 4,40		

- (1) Data regarding the unit without accessories working in maximum power absorption conditions
- (2) Datum related to the unit without accessories working in standard conditions (A35°C; W12/7°C)
- (3) Maximum effective RMS value of the current when the last compressor starts (FLA of the entire unit - FLA of the largest compressor + LRA of the largest compressor)
- (5) These values are determined for cables with operating temperature of 40°C, EPR insulation and a line with a maximum length of 50m. The line section must be determined by a qualified technician based on the protection devices, the length of the line, the type of cable used and the type of installation.
- (6) The correct line protection part must be determined by a qualified technician based on the length of the line, the type of cable used and the type of installation.

KAPPA REV HE (R513A)

			33.2	35.2	37.2	40.2	43.2	51.2	54.2
General electrical specifications									
Max. absorbed power (FLI)	(1)	kW	147,0	168,0	179,7	199,3	218,9	233,2	265,1
Max. absorbed current (FLA)	(1)	A	247,6	279,6	297,2	332,1	367,1	392,6	446,8
Nominal current (Inom)	(2)	A	189,5	204	223,5	247,2	274	294,5	335
cosφ standard unit	(2)		0,83	0,83	0,86	0,85	0,84	0,83	0,83
Nominal current with power factor correction (Inom)	(2)	A	164	178	198	218	239	257	289
cosφ unit with power factor correction	(2)		0,96	0,95	0,97	0,96	0,96	0,95	0,96
Maximum inrush current (MIC)	(3)	A	326	383	400	407	442	499	548
Power supply			400V / 3ph / 50Hz						
Power supply for auxiliary circuits			230V-24V / 1ph / 50Hz						
Suggested line section	(5)	mm²	3x150 + 1x95	3x150 + 1x95	2x(3x70) + 1x70	2x(3x70) + 1x70	2x(3x120) + 1x120	2x(3x120) + 1x120	2x(3x120) + 1x120
Suggested line protection	(6)		NH2gG 315A	NH2gG 315A	NH2gG 400A	NH2gG 400A	NH3gG 500A	NH3gG 500A	NH3gG 500A
Electrical specifications for fans									
Rated power of standard fan		n° x kW	6 x 1,45	7 x 1,45	8 x 1,45	8 x 1,45	8 x 1,45	9 x 1,45	11 x 1,45
Rated current of standard fan		n° x A	6 x 3,40	7 x 3,40	8 x 3,40	8 x 3,40	8 x 3,40	9 x 3,40	11 x 3,40
Rated power of EC fan		n° x kW	6 x 1,25	7 x 1,25	8 x 1,25	8 x 1,25	8 x 1,25	9 x 1,25	11 x 1,25
Rated current of EC fan		n° x A	6 x 1,90	7 x 1,90	8 x 1,90	8 x 1,90	8 x 1,90	9 x 1,90	11 x 1,90
Rated power of oversize EC fans		n° x kW	6 x 2,90	7 x 2,90	8 x 2,90	8 x 2,90	8 x 2,90	9 x 2,90	11 x 2,90
Rated current of oversize EC fans		n° x A	6 x 4,40	7 x 4,40	8 x 4,40	8 x 4,40	8 x 4,40	9 x 4,40	11 x 4,40
			58.2	67.2	73.2	80.2	85.2	90.2	95.2
General electrical specifications									
Max. absorbed power (FLI)	(1)	kW	299,8	316,9	336,3	355,7	384,6	413,6	440,5
Max. absorbed current (FLA)	(1)	A	501,5	527,5	555,9	584,2	637,6	690,9	734,8
Nominal current (Inom)	(2)	A	376,5	397	431,5	465	492,5	521	552,5
cosφ standard unit	(2)		0,85	0,86	0,87	0,88	0,86	0,85	0,86
Nominal current with power factor correction (Inom)	(2)	A	333	351	387	421	436	461	494
cosφ unit with power factor correction	(2)		0,96	0,97	0,97	0,97	0,97	0,96	0,96
Maximum inrush current (MIC)	(3)	A	712	738	771	799	929	982	1.052
Power supply			400V / 3ph / 50Hz			400V / 3ph / 50Hz			
Power supply for auxiliary circuits			230V-24V / 1ph / 50Hz			230V-24V / 1ph / 50Hz			
Suggested line section	(5)	mm²	2x(3x150) + 1x150	2x(3x150) + 1x150	2x(3x150) + 1x150	2x(3x240) + 1x240	2x(3x240) + 1x240	2x(3x240) + 1x240	4x(3x120) + 2x120
Suggested line protection	(6)		NH3gG 630A	NH3gG 630A	NH3gG 630A	NH4gG 800A	NH4gG 800A	NH4gG 800A	NH4gG 1000A
Electrical specifications for fans									
Rated power of standard fan		n° x kW	12 x 1,45	12 x 1,45	13 x 1,45	14 x 1,45	15 x 1,45	16 x 1,45	17 x 1,45
Rated current of standard fan		n° x A	12 x 3,40	12 x 3,40	13 x 3,40	14 x 3,40	15 x 3,40	16 x 3,40	17 x 3,40
Rated power of EC fan		n° x kW	12 x 1,25	12 x 1,25	13 x 1,25	14 x 1,25	15 x 1,25	16 x 1,25	17 x 1,25
Rated current of EC fan		n° x A	12 x 1,90	12 x 1,90	13 x 1,90	14 x 1,90	15 x 1,90	16 x 1,90	17 x 1,90
Rated power of oversize EC fans		n° x kW	12 x 2,90	12 x 2,90	13 x 2,90	14 x 2,90	15 x 2,90	16 x 2,90	17 x 2,90
Rated current of oversize EC fans		n° x A	12 x 4,40	12 x 4,40	13 x 4,40	14 x 4,40	15 x 4,40	16 x 4,40	17 x 4,40

(1) Data regarding the unit without accessories working in maximum power absorption conditions

(2) Datum related to the unit without accessories working in standard conditions (A35°C; W12/7°C)

(3) Maximum effective RMS value of the current when the last compressor starts (FLA of the entire unit - FLA of the largest compressor + LRA of the largest compressor)

(5) These values are determined for cables with operating temperature of 40°C, EPR insulation and a line with a maximum length of 50m. The line section must be determined by a qualified technician based on the protection devices, the length of the line, the type of cable used and the type of installation.

(6) The correct line protection part must be determined by a qualified technician based on the length of the line, the type of cable used and the type of installation.

KAPPA REV HE (R513A)

			100.2	105.2	115.2	120.2	134.4	146.4	160.4
General electrical specifications									
Max. absorbed power (FLI)	(1)	kW	467,4	497,9	529,9	569,6	633,8	672,6	711,4
Max. absorbed current (FLA)	(1)	A	778,8	826,9	878,4	954,6	1.055,0	1.111,8	1.168,5
Nominal current (Inom)	(2)	A	583	622,5	665	720,5	788,5	856	924,5
cosφ standard unit	(2)		0,86	0,86	0,86	0,85	-	-	-
Nominal current with power factor correction (Inom)	(2)	A	527	563	602	644	-	-	-
cosφ unit with power factor correction	(2)		0,95	0,95	0,95	0,95	-	-	-
Maximum inrush current (MIC)	(3)	A	1.096	1.261	1.312	1.468	1.265	1.327	1.384
Power supply			400V / 3ph / 50Hz						
Power supply for auxiliary circuits			230V-24V / 1ph / 50Hz						
Suggested line section	(5)	mm²	4x(3x150) + 2x150	4x(3x150) + 2x150	4x(3x150) + 2x150	4x(3x150) + 2x150			
Suggested line protection	(6)		NH4gG 1250A	NH4gG 1250A	NH4gG 1250A	NH4gG 1250A			
Electrical specifications for fans									
Rated power of standard fan		n° x kW	18 x 1,45	19 x 1,45	21 x 1,45	22 x 1,45	24 x 1,45	26 x 1,45	28 x 1,45
Rated current of standard fan		n° x A	18 x 3,40	19 x 3,40	21 x 3,40	22 x 3,40	24 x 3,40	26 x 3,40	28 x 3,40
Rated power of EC fan		n° x kW	18 x 1,25	19 x 1,25	21 x 1,25	22 x 1,25	24 x 1,25	26 x 1,25	28 x 1,25
Rated current of EC fan		n° x A	18 x 1,90	19 x 1,90	21 x 1,90	22 x 1,90	24 x 1,90	26 x 1,90	28 x 1,90
Rated power of oversize EC fans		n° x kW	18 x 2,90	19 x 2,90	21 x 2,90	22 x 2,90	24 x 2,90	26 x 2,90	28 x 2,90
Rated current of oversize EC fans		n° x A	18 x 4,40	19 x 4,40	21 x 4,40	22 x 4,40	24 x 4,40	26 x 4,40	28 x 4,40

(1) Data regarding the unit without accessories working in maximum power absorption conditions

(2) Datum related to the unit without accessories working in standard conditions (A35°C; W12/7°C)

(3) Maximum effective RMS value of the current when the last compressor starts (FLA of the entire unit - FLA of the largest compressor + LRA of the largest compressor)

(5) These values are determined for cables with operating temperature of 40°C, EPR insulation and a line with a maximum length of 50m. The line section must be determined by a qualified technician based on the protection devices, the length of the line, the type of cable used and the type of installation.

(6) The correct line protection part must be determined by a qualified technician based on the length of the line, the type of cable used and the type of installation.

KAPPA REV SLN (R513A)

			33.2	35.2	37.2	40.2	43.2	51.2	54.2
General electrical specifications									
Max. absorbed power (FLI)	(1)	kW	147,0	168,0	179,7	199,3	218,9	233,2	265,1
Max. absorbed current (FLA)	(1)	A	247,6	279,6	297,2	332,1	367,1	392,6	446,8
Nominal current (Inom)	(2)	A	194	209	228	251,4	280	301	341
cosφ standard unit	(2)		0,83	0,83	0,86	0,85	0,84	0,83	0,83
Nominal current with power factor correction (Inom)	(2)	A	163	178	198	218	239	257	289
cosφ unit with power factor correction	(2)		0,96	0,95	0,97	0,96	0,96	0,95	0,96
Maximum inrush current (MIC)	(3)	A	326	383	400	407	442	499	548
Power supply			400V / 3ph / 50Hz						
Power supply for auxiliary circuits			230V-24V / 1ph / 50Hz						
Suggested line section	(5)	mm ²	3x150 + 1x95	3x150 + 1x95	2x(3x70) + 1x70	2x(3x70) + 1x70	2x(3x120) + 1x120	2x(3x120) + 1x120	2x(3x120) + 1x120
Suggested line protection	(6)		NH2gG 315A	NH2gG 315A	NH2gG 400A	NH2gG 400A	NH3gG 500A	NH3gG 500A	NH3gG 500A
Electrical specifications for fans									
Rated power of standard fan		n° x kW	6 x 1,45	7 x 1,45	8 x 1,45	8 x 1,45	8 x 1,45	9 x 1,45	11 x 1,45
Rated current of standard fan		n° x A	6 x 3,40	7 x 3,40	8 x 3,40	8 x 3,40	8 x 3,40	9 x 3,40	11 x 3,40
Rated power of EC fan		n° x kW	6 x 1,25	7 x 1,25	8 x 1,25	8 x 1,25	8 x 1,25	9 x 1,25	11 x 1,25
Rated current of EC fan		n° x A	6 x 1,90	7 x 1,90	8 x 1,90	8 x 1,90	8 x 1,90	9 x 1,90	11 x 1,90
Rated power of oversize EC fans		n° x kW	6 x 2,90	7 x 2,90	8 x 2,90	8 x 2,90	8 x 2,90	9 x 2,90	11 x 2,90
Rated current of oversize EC fans		n° x A	6 x 4,40	7 x 4,40	8 x 4,40	8 x 4,40	8 x 4,40	9 x 4,40	11 x 4,40
			58.2	67.2	73.2	80.2	85.2	90.2	95.2
General electrical specifications									
Max. absorbed power (FLI)	(1)	kW	299,8	316,9	336,3	355,7	384,6	413,6	440,5
Max. absorbed current (FLA)	(1)	A	501,5	527,5	555,9	584,2	637,6	690,9	734,8
Nominal current (Inom)	(2)	A	383	403	438	471	499	527	559
cosφ standard unit	(2)		0,85	0,86	0,87	0,88	0,86	0,85	0,86
Nominal current with power factor correction (Inom)	(2)	A	333	351	387	421	436	461	494
cosφ unit with power factor correction	(2)		0,96	0,97	0,97	0,97	0,97	0,96	0,96
Maximum inrush current (MIC)	(3)	A	712	738	771	799	929	982	1.052
Power supply			400V / 3ph / 50Hz			400V / 3ph / 50Hz			
Power supply for auxiliary circuits			230V-24V / 1ph / 50Hz			230V-24V / 1ph / 50Hz			
Suggested line section	(5)	mm ²	2x(3x150) + 1x150	2x(3x150) + 1x150	2x(3x150) + 1x150	2x(3x240) + 1x240	2x(3x240) + 1x240	2x(3x240) + 1x240	4x(3x120) + 2x120
Suggested line protection	(6)		NH3gG 630A	NH3gG 630A	NH3gG 630A	NH4gG 800A	NH4gG 800A	NH4gG 800A	NH4gG 1000A
Electrical specifications for fans									
Rated power of standard fan		n° x kW	12 x 1,45	12 x 1,45	13 x 1,45	14 x 1,45	15 x 1,45	16 x 1,45	17 x 1,45
Rated current of standard fan		n° x A	12 x 3,40	12 x 3,40	13 x 3,40	14 x 3,40	15 x 3,40	16 x 3,40	17 x 3,40
Rated power of EC fan		n° x kW	12 x 1,25	12 x 1,25	13 x 1,25	14 x 1,25	15 x 1,25	16 x 1,25	17 x 1,25
Rated current of EC fan		n° x A	12 x 1,90	12 x 1,90	13 x 1,90	14 x 1,90	15 x 1,90	16 x 1,90	17 x 1,90
Rated power of oversize EC fans		n° x kW	12 x 2,90	12 x 2,90	13 x 2,90	14 x 2,90	15 x 2,90	16 x 2,90	17 x 2,90
Rated current of oversize EC fans		n° x A	12 x 4,40	12 x 4,40	13 x 4,40	14 x 4,40	15 x 4,40	16 x 4,40	17 x 4,40

- (1) Data regarding the unit without accessories working in maximum power absorption conditions
- (2) Datum related to the unit without accessories working in standard conditions (A35°C; W12/7°C)
- (3) Maximum effective RMS value of the current when the last compressor starts (FLA of the entire unit - FLA of the largest compressor + LRA of the largest compressor)
- (5) These values are determined for cables with operating temperature of 40°C, EPR insulation and a line with a maximum length of 50m. The line section must be determined by a qualified technician based on the protection devices, the length of the line, the type of cable used and the type of installation.
- (6) The correct line protection part must be determined by a qualified technician based on the length of the line, the type of cable used and the type of installation.

KAPPA REV SLN (R513A)

			100.2	105.2	115.2	120.2	134.4	146.4	160.4
General electrical specifications									
Max. absorbed power (FLI)	(1)	kW	467,4	497,9	529,9	569,6	633,8	672,6	711,4
Max. absorbed current (FLA)	(1)	A	778,8	826,9	878,4	954,6	1.055,0	1.111,8	1.168,5
Nominal current (Inom)	(2)	A	589	629	671	727	795	862	931
cosφ standard unit	(2)		0,86	0,86	0,86	0,85	-	-	-
Nominal current with power factor correction (Inom)	(2)	A	527	563	602	644	-	-	-
cosφ unit with power factor correction	(2)		0,95	0,95	0,95	0,95	-	-	-
Maximum inrush current (MIC)	(3)	A	1.096	1.261	1.312	1.468	1.265	1.327	1.384
Power supply			400V / 3ph / 50Hz						
Power supply for auxiliary circuits			230V-24V / 1ph / 50Hz						
Suggested line section	(5)	mm²	4x(3x150) + 2x150	4x(3x150) + 2x150	4x(3x150) + 2x150	4x(3x150) + 2x150			
Suggested line protection	(6)		NH4gG 1250A	NH4gG 1250A	NH4gG 1250A	NH4gG 1250A			
Electrical specifications for fans									
Rated power of standard fan		n° x kW	18 x 1,45	19 x 1,45	21 x 1,45	22 x 1,45	24 x 1,45	26 x 1,45	28 x 1,45
Rated current of standard fan		n° x A	18 x 3,40	19 x 3,40	21 x 3,40	22 x 3,40	24 x 3,40	26 x 3,40	28 x 3,40
Rated power of EC fan		n° x kW	18 x 1,25	19 x 1,25	21 x 1,25	22 x 1,25	24 x 1,25	26 x 1,25	28 x 1,25
Rated current of EC fan		n° x A	18 x 1,90	19 x 1,90	21 x 1,90	22 x 1,90	24 x 1,90	26 x 1,90	28 x 1,90
Rated power of oversize EC fans		n° x kW	18 x 2,90	19 x 2,90	21 x 2,90	22 x 2,90	24 x 2,90	26 x 2,90	28 x 2,90
Rated current of oversize EC fans		n° x A	18 x 4,40	19 x 4,40	21 x 4,40	22 x 4,40	24 x 4,40	26 x 4,40	28 x 4,40

(1) Data regarding the unit without accessories working in maximum power absorption conditions

(2) Datum related to the unit without accessories working in standard conditions (A35°C; W12/7°C)

(3) Maximum effective RMS value of the current when the last compressor starts (FLA of the entire unit - FLA of the largest compressor + LRA of the largest compressor)

(5) These values are determined for cables with operating temperature of 40°C, EPR insulation and a line with a maximum length of 50m. The line section must be determined by a qualified technician based on the protection devices, the length of the line, the type of cable used and the type of installation.

(6) The correct line protection part must be determined by a qualified technician based on the length of the line, the type of cable used and the type of installation.

HYDRAULIC MODULES

KAPPA REV

			33.2	35.2	37.2	40.2	43.2	51.2	54.2	58.2
Volume of the expansion vessel		l	24	24	24	24	24	24	24	24
Volume of the buffer tank		l	-	-	-	-	-	740	740	740
Standard pumps										
Pump model 1P			P2	P2	P2	P3	P3	P8	P8	P9
Pump model 2P			P2	P2	P2	P3	P3	P8	P8	P9
Available head 1P	(1)	kPa	208	186	162	194	179	214	188	232
Available head 2P	(1)	kPa	186	160	132	160	157	189	159	198
Oversize pumps										
Pump model 1PM			P3	P3	P3	P6	P6	P9	P9	P11
Pump model 2PM			P3	P3	P3	P6	P6	P9	P9	P11
Available head 1PM	(1)	kPa	272	251	226	275	251	262	237	301
Available head 2PM	(1)	kPa	249	224	196	240	229	238	208	267
Pumps for glycol										
Pump model 1PG			P4	P5	P5	P10	P10	P10	P10	P13
Pump model 2PG			P4	P5	P5	P10	P10	P10	P10	P13
Available head 1PG	(1)	kPa	190	229	193	190	216	190	160	216
Available head 2PG	(1)	kPa	157	190	146	135	184	155	118	164
			67.2	73.2	80.2	85.2	90.2	95.2	100.2	105.2
Volume of the expansion vessel		l	24	24	24	24	24	24	24	24
Volume of the buffer tank		l	740	900	900	900	900	900	900	900
Standard pumps										
Pump model 1P			P9	P13	P13	P13	P13	P13	P13	P14
Pump model 2P			P9	P13	P13	P13	P13	P13	P13	P14
Available head 1P	(1)	kPa	185	209	217	205	191	180	159	204
Available head 2P	(1)	kPa	169	192	198	185	169	158	132	176
Oversize pumps										
Pump model 1PM			P11	P14	P14	P14	P14	P14	P14	P18
Pump model 2PM			P11	P14	P14	P14	P14	P14	P14	P18
Available head 1PM	(1)	kPa	266	258	266	255	241	230	209	265
Available head 2PM	(1)	kPa	250	241	247	234	218	208	182	237
Pumps for glycol										
Pump model 1PG			P13	P15	P15	P16	P16	P21	P21	P21
Pump model 2PG			P13	P15	P15	P16	P16	P21	P21	P21
Available head 1PG	(1)	kPa	196	182	198	-	-	-	-	-
Available head 2PG	(1)	kPa	174	158	171	-	-	-	-	-
			115.2	120.2	130.2	140.3	150.3	160.3	108.4	
Volume of the expansion vessel		l	24	24	24	24	24	24	24	-
Volume of the buffer tank		l	900	1000	1000	-	-	-	-	-
Standard pumps										
Pump model 1P			P14	P19	P19	P19	P19	P19	P19	-
Pump model 2P			P14	P19	P19	P19	P19	P19	P19	-
Available head 1P	(1)	kPa	214	226	211	190	186	177	177	-
Available head 2P	(1)	kPa	183	190	173	166	159	149	149	-
Oversize pumps										
Pump model 1PM			P18	P20	P20	P20	P20	P20	P20	-
Pump model 2PM			P18	P20	P20	P20	P20	P20	P20	-
Available head 1PM	(1)	kPa	271	322	309	289	286	277	277	-
Available head 2PM	(1)	kPa	240	287	270	265	259	250	250	-
Pumps for glycol										
Pump model 1PG			P21	P22	P22	P22	P22	P22	P22	-
Pump model 2PG			P21	P22	P22	P22	P22	P22	P22	-
Available head 1PG	(1)	kPa	-	-	-	-	-	-	-	-
Available head 2PG	(1)	kPa	-	-	-	-	-	-	-	-

(1) External air temperature 35°C, user-side heat exchanger water inlet/outlet temperature 12/7°C.

KAPPA REV

			116.4	134.4	146.4	160.4	170.4	180.4	190.4	200.4
Volume of the expansion vessel		l	2 x 24	2 x 24	2 x 24	2 x 24	2 x 24	2 x 24	2 x 24	2 x 24
Volume of the buffer tank		l	-	-	-	-	2 x 900	2 x 900	2 x 900	2 x 900
Standard pumps										
Pump model 1P			P9	P9	P13	P13	P13	P13	P13	P13
Pump model 2P			P9	P9	P13	P13	P13	P13	P13	P13
Available head 1P	(1)	kPa	232	185	209	217	205	191	180	159
Available head 2P	(1)	kPa	198	169	192	198	185	169	158	132
Oversize pumps										
Pump model 1PM			P11	P11	P14	P14	P14	P14	P14	P14
Pump model 2PM			P11	P11	P14	P14	P14	P14	P14	P14
Available head 1PM	(1)	kPa	301	266	258	266	255	241	230	209
Available head 2PM	(1)	kPa	267	250	241	247	234	218	208	182
Pumps for glycol										
Pump model 1PG			P13	P13	P15	P15	P16	P16	P21	P21
Pump model 2PG			P13	P13	P15	P15	P16	P16	P21	P21
Available head 1PG	(1)	kPa	216	196	182	198	-	-	-	-
Available head 2PG	(1)	kPa	164	174	158	171	-	-	-	-

(1) External air temperature 35°C, user-side heat exchanger water inlet/outlet temperature 12/7°C.

KAPPA REV HE

			33.2	35.2	37.2	40.2	43.2	51.2	54.2	
Volume of the expansion vessel		l	24	24	24	24	24	24	24	
Volume of the buffer tank		l	-	740	740	740	740	740	740	
Standard pumps										
Pump model 1P			P2	P2	P2	P3	P3	P8	P8	
Pump model 2P			P2	P2	P2	P3	P3	P8	P8	
Available head 1P	(1)	kPa	193	188	173	183	141	216	192	
Available head 2P	(1)	kPa	168	157	139	140	116	189	159	
Oversize pumps										
Pump model 1PM			P3	P3	P3	P6	P6	P9	P9	
Pump model 2PM			P3	P3	P3	P6	P6	P9	P9	
Available head 1PM	(1)	kPa	257	253	238	258	207	265	241	
Available head 2PM	(1)	kPa	232	222	204	215	182	238	208	
Pumps for glycol										
Pump model 1PG			P5	P5	P5	P10	P10	P10	P10	
Pump model 2PG			P5	P5	P5	P10	P10	P10	P10	
Available head 1PG	(1)	kPa	235	231	215	209	186	200	168	
Available head 2PG	(1)	kPa	199	183	161	144	111	160	119	
Standard pumps										
Volume of the expansion vessel		l	24	24	24	24	24	24	24	
Volume of the buffer tank		l	740	740	900	900	900	900	900	
Standard pumps										
Pump model 1P			P9	P9	P13	P13	P13	P13	P13	
Pump model 2P			P9	P9	P13	P13	P13	P13	P13	
Available head 1P	(1)	kPa	203	180	220	210	191	171	160	
Available head 2P	(1)	kPa	156	163	202	190	168	146	132	
Oversize pumps										
Pump model 1PM			P11	P11	P14	P14	P14	P14	P14	
Pump model 2PM			P11	P11	P14	P14	P14	P14	P14	
Available head 1PM	(1)	kPa	282	268	270	259	240	221	210	
Available head 2PM	(1)	kPa	235	251	251	239	218	196	182	
Pumps for glycol										
Pump model 1PG			P13	P13	P15	P15	P16	P16	P21	
Pump model 2PG			P13	P13	P15	P15	P16	P16	P21	
Available head 1PG	(1)	kPa	217	213	202	185	-	-	-	
Available head 2PG	(1)	kPa	147	142	176	155	-	-	-	

(1) External air temperature 35°C, user-side heat exchanger water inlet/outlet temperature 12/7°C.

KAPPA REV HE

			100.2	105.2	115.2	120.2	80.4	86.4	102.4
Volume of the expansion vessel		l	24	24	24	24	-	-	2 x 24
Volume of the buffer tank		l	900	900	900	1000	-	-	-
Standard pumps									
Pump model 1P			P13	P14	P14	P19	-	-	P8
Pump model 2P			P13	P14	P14	P19	-	-	P8
Available head 1P	(1)	kPa	142	207	188	210	-	-	216
Available head 2P	(1)	kPa	112	176	153	171	-	-	189
Oversize pumps									
Pump model 1PM			P14	P18	P18	P20	-	-	P9
Pump model 2PM			P14	P18	P18	P20	-	-	P9
Available head 1PM	(1)	kPa	193	264	241	307	-	-	265
Available head 2PM	(1)	kPa	162	232	206	268	-	-	238
Pumps for glycol									
Pump model 1PG			P21	P21	P21	P22	-	-	P10
Pump model 2PG			P21	P21	P21	P22	-	-	P10
Available head 1PG	(1)	kPa	-	-	-	-	-	-	200
Available head 2PG	(1)	kPa	-	-	-	-	-	-	160
			108.4	116.4	134.4	146.4			160.4
Volume of the expansion vessel		l	2 x 24	2 x 24	2 x 24	2 x 24	2 x 24	2 x 24	2 x 24
Volume of the buffer tank		l	-	-	2 x 740	2 x 900	2 x 900	2 x 900	2 x 900
Standard pumps									
Pump model 1P			P8	P9	P9	P9	P13	P13	P13
Pump model 2P			P8	P9	P9	P9	P13	P13	P13
Available head 1P	(1)	kPa	192	203	180	180	220	210	210
Available head 2P	(1)	kPa	159	156	163	163	202	190	190
Oversize pumps									
Pump model 1PM			P9	P11	P11	P11	P14	P14	P14
Pump model 2PM			P9	P11	P11	P11	P14	P14	P14
Available head 1PM	(1)	kPa	241	282	268	268	270	259	259
Available head 2PM	(1)	kPa	208	235	251	251	251	239	239
Pumps for glycol									
Pump model 1PG			P10	P13	P13	P13	P15	P15	P15
Pump model 2PG			P10	P13	P13	P13	P15	P15	P15
Available head 1PG	(1)	kPa	168	217	213	213	202	185	185
Available head 2PG	(1)	kPa	119	147	142	142	176	155	155

(1) External air temperature 35°C, user-side heat exchanger water inlet/outlet temperature 12/7°C.

KAPPA REV SLN

			33.2	35.2	37.2	40.2	43.2	51.2	54.2
Volume of the expansion vessel		l	24	24	24	24	24	24	24
Volume of the buffer tank		l	-	740	740	740	740	740	740
Standard pumps									
Pump model 1P			P2	P2	P2	P3	P3	P8	P8
Pump model 2P			P2	P2	P2	P3	P3	P8	P8
Available head 1P	(1)	kPa	193	188	173	183	141	216	192
Available head 2P	(1)	kPa	168	157	139	140	116	189	159
Oversize pumps									
Pump model 1PM			P3	P3	P3	P6	P6	P9	P9
Pump model 2PM			P3	P3	P3	P6	P6	P9	P9
Available head 1PM	(1)	kPa	257	253	238	258	207	265	241
Available head 2PM	(1)	kPa	232	222	204	215	182	238	208
Pumps for glycol									
Pump model 1PG			P5	P5	P5	P10	P10	P10	P10
Pump model 2PG			P5	P5	P5	P10	P10	P10	P10
Available head 1PG	(1)	kPa	235	231	215	209	186	200	168
Available head 2PG	(1)	kPa	199	183	161	144	111	160	119

(1) External air temperature 35°C, user-side heat exchanger water inlet/outlet temperature 12/7°C.

KAPPA REV SLN

			58.2	67.2	73.2	80.2	85.2	90.2	95.2
Volume of the expansion vessel		l	24	24	24	24	24	24	24
Volume of the buffer tank		l	740	740	900	900	900	900	900
Standard pumps									
Pump model 1P			P9	P9	P13	P13	P13	P13	P13
Pump model 2P			P9	P9	P13	P13	P13	P13	P13
Available head 1P	(1)	kPa	203	180	220	210	191	171	160
Available head 2P	(1)	kPa	156	163	202	190	168	146	132
Oversize pumps									
Pump model 1PM			P11	P11	P14	P14	P14	P14	P14
Pump model 2PM			P11	P11	P14	P14	P14	P14	P14
Available head 1PM	(1)	kPa	282	268	270	259	240	221	210
Available head 2PM	(1)	kPa	235	251	251	239	218	196	182
Pumps for glycol									
Pump model 1PG			P13	P13	P15	P15	P16	P16	P21
Pump model 2PG			P13	P13	P15	P15	P16	P16	P21
Available head 1PG	(1)	kPa	217	213	202	185	-	-	-
Available head 2PG	(1)	kPa	147	142	176	155	-	-	-
			100.2	105.2	115.2	120.2	80.4	86.4	102.4
Volume of the expansion vessel		l	24	24	24	24	-	-	2 x 24
Volume of the buffer tank		l	900	900	900	1000	-	-	-
Standard pumps									
Pump model 1P			P13	P14	P14	P19	-	-	P8
Pump model 2P			P13	P14	P14	P19	-	-	P8
Available head 1P	(1)	kPa	142	207	188	210	-	-	216
Available head 2P	(1)	kPa	112	176	153	171	-	-	189
Oversize pumps									
Pump model 1PM			P14	P18	P18	P20	-	-	P9
Pump model 2PM			P14	P18	P18	P20	-	-	P9
Available head 1PM	(1)	kPa	193	264	241	307	-	-	265
Available head 2PM	(1)	kPa	162	232	206	268	-	-	238
Pumps for glycol									
Pump model 1PG			P21	P21	P21	P22	-	-	P10
Pump model 2PG			P21	P21	P21	P22	-	-	P10
Available head 1PG	(1)	kPa	-	-	-	-	-	-	200
Available head 2PG	(1)	kPa	-	-	-	-	-	-	160
			108.4	116.4	134.4	146.4	160.4		
Volume of the expansion vessel		l	2 x 24	2 x 24	2 x 24	2 x 24	2 x 24	2 x 24	2 x 24
Volume of the buffer tank		l	-	-	2 x 740	2 x 900	2 x 900	2 x 900	2 x 900
Standard pumps									
Pump model 1P			P8	P9	P9	P13	P13	P13	P13
Pump model 2P			P8	P9	P9	P13	P13	P13	P13
Available head 1P	(1)	kPa	192	203	180	220	210	210	210
Available head 2P	(1)	kPa	159	156	163	202	190	190	190
Oversize pumps									
Pump model 1PM			P9	P11	P11	P14	P14	P14	P14
Pump model 2PM			P9	P11	P11	P14	P14	P14	P14
Available head 1PM	(1)	kPa	241	282	268	270	259	259	259
Available head 2PM	(1)	kPa	208	235	251	251	239	239	239
Pumps for glycol									
Pump model 1PG			P10	P13	P13	P15	P15	P15	P15
Pump model 2PG			P10	P13	P13	P15	P15	P15	P15
Available head 1PG	(1)	kPa	168	217	213	202	185	185	185
Available head 2PG	(1)	kPa	119	147	142	176	155	155	155

(1) External air temperature 35°C, user-side heat exchanger water inlet/outlet temperature 12/7°C.

PUMP DATA

Model	Rated power	Rated current	Min. flow rate	Max. flow rate
	kW	A	m ³ /h	m ³ /h
P1	4,0	8,7	24	72
P2	5,5	10	24	87
P3	7,5	14	24	87
P4	7,5	14	24	87
P5	9,2	17	30	72
P6	9,2	17	30	72
P7	7,5	14	42	132
P8	9,2	17	42	132
P9	11	21	42	138
P10	11	21	42	138
P11	15	0	35	157
P12	11	20	58	237
P13	15	27	65	255
P14	19	33	70	270
P15	19	33	70	270
P16	22	40	75	280
P17	22	40	75	280
P18	22	40	50	233
P19	22	40	76	324
P20	30	54	76	359
P21	30	54	76	359
P22	37	66	76	324

USER-SIDE EXCHANGER FLOW RATE FIELDS

The units are sized and optimized for the following nominal conditions: external air 35°C, inlet/outlet of the user-side heat exchanger 12/7°C.

The units can work at design conditions different from nominal conditions, provided that:

- the design condition falls within the operating limits specified below
- the unit is equipped with all the accessories necessary for operation of the unit (e.g. brine kit, fan speed adjuster, HAT)
- the flow rate at design conditions (that is, of the specific application) must always come within the allowed flow rate ranges specified below. If the design conditions require a water flow rate that does not come within the allowed operating range, you must contact our sales department that will identify the most suitable solution for the specific application.

KAPPA REV

	Qmin	Qmax
	m ³ /h	m ³ /h
33.2	26,5	79,5
35.2	29,3	87,8
37.2	32,1	96,2
40.2	35,2	105,7
43.2	39,5	118,4
51.2	41,6	124,7
54.2	46,4	139,1
58.2	52,7	158,0
67.2	59,3	177,8
73.2	63,3	189,9
80.2	67,7	203,0
85.2	72,2	216,6
90.2	76,5	229,5
95.2	81,9	245,6
100.2	85,6	256,7
105.2	90,0	270,0
115.2	95,9	287,8
120.2	103,5	310,5
130.2	111,0	333,1
140.3	124,0	371,9
150.3	129,0	387,0
160.3	132,9	398,8
108.4	89,2	267,5
116.4	101,1	303,2
134.4	113,8	341,5
146.4	121,7	365,2
160.4	130,3	391,0
170.4	146,8	440,5
180.4	155,6	466,7
190.4	166,5	499,4
200.4	174,0	521,9

KAPPA REV HE

	Qmin	Qmax
	m ³ /h	m ³ /h
33.2	28,3	84,8
35.2	31,6	94,7
37.2	33,3	100,0
40.2	38,0	114,0
43.2	42,3	127,0
51.2	44,5	133,6
54.2	49,3	147,9
58.2	57,9	173,8
67.2	62,9	188,8
73.2	66,2	198,7
80.2	70,0	209,9
85.2	76,2	228,5
90.2	82,0	245,9
95.2	88,0	264,1
100.2	93,3	280,0
105.2	98,0	294,1
115.2	103,9	311,7
120.2	111,8	335,5
80.4	73,4	220,2
86.4	81,7	245,0
102.4	86,0	258,1
108.4	95,4	286,3
116.4	111,8	335,4
134.4	125,9	377,7
146.4	132,4	397,3
160.4	139,9	419,8

KAPPA REV SLN

	Qmin	Qmax
	m ³ /h	m ³ /h
33.2	27,2	81,7
35.2	30,5	91,4
37.2	32,3	96,9
40.2	36,6	109,8
43.2	40,6	121,8
51.2	42,9	128,6
54.2	47,7	143,0
58.2	55,8	167,3
67.2	60,5	181,4
73.2	63,6	190,9
80.2	67,4	202,1
85.2	73,4	220,1
90.2	79,0	237,1
95.2	84,8	254,3
100.2	89,9	269,6
105.2	94,4	283,2
115.2	100,3	301,0
120.2	107,8	323,4
80.4	70,8	212,5
86.4	78,5	235,6
102.4	82,9	248,7
108.4	92,4	277,3
116.4	107,9	323,8
134.4	121,0	362,9
146.4	127,3	381,8
160.4	134,7	404,2

OPERATING LIMITS

KAPPA REV COOLING

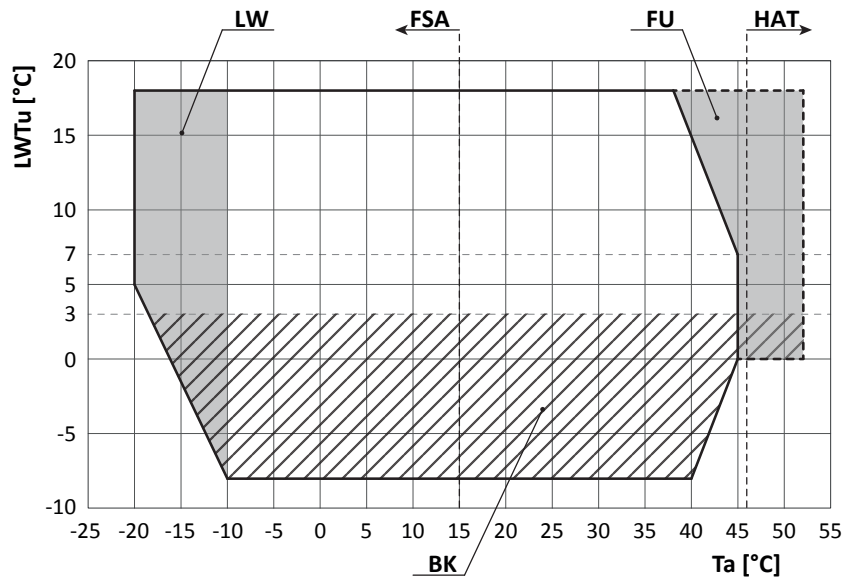

HEATING

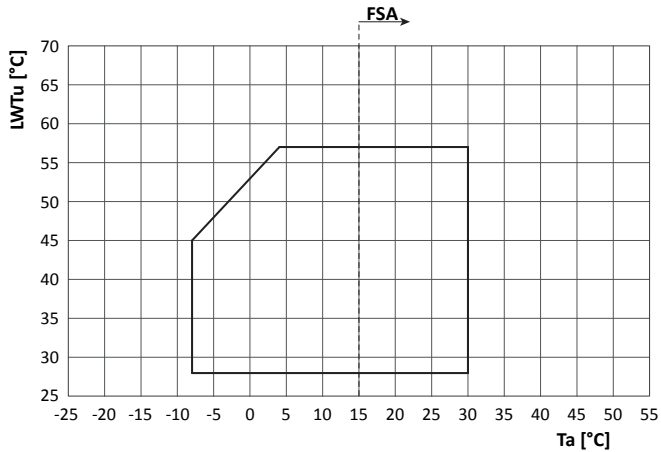

TOTAL RECOVERY

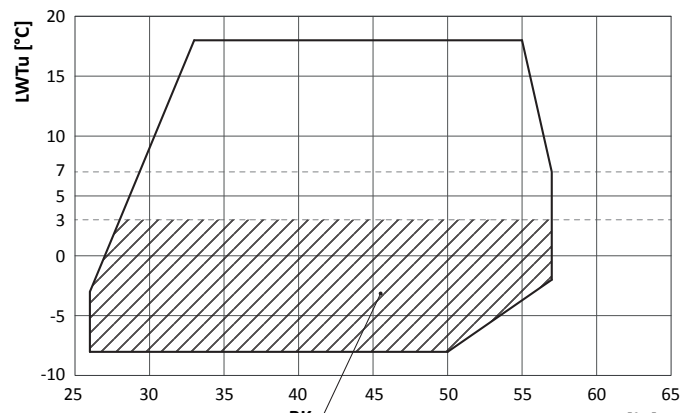

- Ta:** external air temperature
- LWTu:** water outlet temperature from the user-side heat exchanger
- LWTr:** water outlet temperature from the recovery exchanger
- FSA:** to work in the area indicated by the arrow, it is mandatory to include the "Fan speed adjuster" accessory or the "EC fans" accessory
- LW:** in the indicated area, the unit can work only where there is no wind
- HAT:** the "HAT" accessory is obligatory in the area indicated by the arrow. With this accessory, operation is guaranteed with external air temperature up to 52°C. For higher temperatures up to about 55°C, a set-up with air conditioning of the electrical control panel is necessary; the unit works in capacity reduction mode. The feasibility of this set-up must be assessed: please contact our sales department.
- HWT:** in the indicated area, the unit can work only if fitted with the "HWT" accessory
- FU:** in the indicated area, the control could actuate a forced capacity reduction of the compressors so as to prevent tripping of the safety devices
- BK:** For LWTu below +3°C, it is mandatory to fit the "Brine Kit" accessory

For LWTu below +5°C, it is compulsory to use suitable percentages of antifreeze additives (glycols) to prevent ice formation in the exchanger.

The inlet and outlet temperatures of the user-side exchanger must be given on ordering to allow correct setting of the alarm parameters and verification of the sizing of the expansion valve.

The cooling set point can then be changed by the customer in an interval that, compared to the set point given on ordering, ranges from -1K up to the maximum temperature allowed by the above-stated operating limits.

The unit will be optimized to work at the set point temperatures given on ordering. For different set points, the cooling capacity provided and the level of efficiency of the machine could decrease and move away from these conditions.

KAPPA REV HE - KAPPA REV SLN COOLING

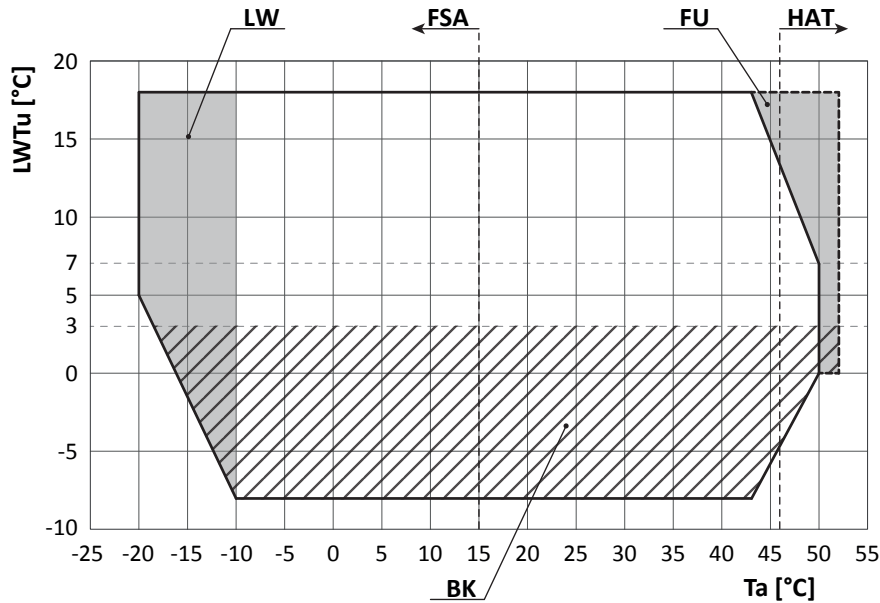

HEATING

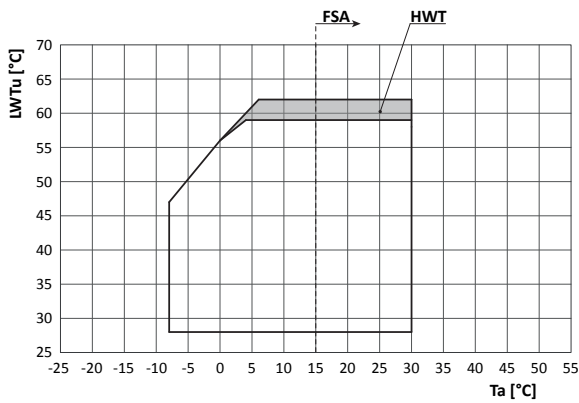

TOTAL RECOVERY

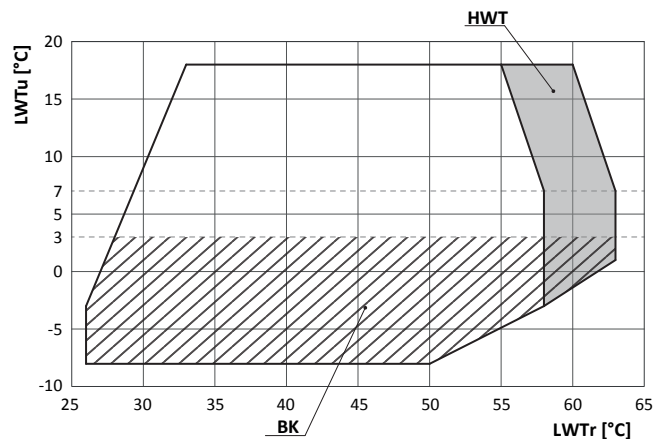

Ta: external air temperature

LWTu: water outlet temperature from the user-side heat exchanger

LWTr: water outlet temperature from the recovery exchanger

FSA: to work in the area indicated by the arrow, it is mandatory to include the "Fan speed adjuster" accessory or the "EC fans" accessory

LW: in the indicated area, the unit can work only where there is no wind

HAT: the "HAT" accessory is obligatory in the area indicated by the arrow. With this accessory, operation is guaranteed with external air temperature up to 52°C. For higher temperatures up to about 55°C, a set-up with air conditioning of the electrical control panel is necessary; the unit works in capacity reduction mode. The feasibility of this set-up must be assessed: please contact our sales department.

HWT: in the indicated area, the unit can work only if fitted with the "HWT" accessory

FU: in the indicated area, the control could actuate a forced capacity reduction of the compressors so as to prevent tripping of the safety devices

BK: For LWTu below +3°C, it is mandatory to fit the "Brine Kit" accessory

For LWTu below +5°C, it is compulsory to use suitable percentages of antifreeze additives (glycols) to prevent ice formation in the exchanger.

The inlet and outlet temperatures of the user-side exchanger must be given on ordering to allow correct setting of the alarm parameters and verification of the sizing of the expansion valve.

The cooling set point can then be changed by the customer in an interval that, compared to the set point given on ordering, ranges from -1K up to the maximum temperature allowed by the above-stated operating limits.

The unit will be optimized to work at the set point temperatures given on ordering. For different set points, the cooling capacity provided and the level of efficiency of the machine could decrease and move away from these conditions.

NOISE LEVELS

KAPPA REV

	Octave bands [dB]																Total [dB(A)]	
	63 Hz		125 Hz		250 Hz		500 Hz		1000 Hz		2000 Hz		4000 Hz		8000 Hz		Lw_tot	Lp_tot
	Lw	Lp	Lw	Lp	Lw	Lp	Lw	Lp	Lw	Lp	Lw	Lp	Lw	Lp	Lw	Lp		
33.2	71	39	74	42	89	57	90	58	91	59	86	54	79	47	71	39	94	62
35.2	73	41	82	50	90	58	91	59	92	60	87	55	79	47	71	39	95	63
37.2	73	41	84	52	90	58	91	59	92	60	88	56	78	46	70	38	95	63
40.2	70	38	79	47	88	56	95	63	93	61	86	54	76	44	68	36	96	64
43.2	66	34	67	35	86	54	95	63	93	61	85	53	74	42	67	35	96	64
51.2	68	36	71	39	87	55	95	63	94	62	88	55	75	42	68	35	97	65
54.2	76	44	77	45	87	55	95	62	95	63	90	58	76	44	70	37	98	66
58.2	77	45	87	55	94	61	95	62	96	63	88	56	80	48	71	39	98	66
67.2	77	44	90	58	97	64	94	62	97	64	88	56	83	51	73	40	99	67
73.2	77	44	90	58	99	66	96	63	97	65	90	57	83	50	73	41	100	67
80.2	76	43	88	56	100	67	97	64	97	64	90	58	82	49	73	41	100	67
85.2	76	43	87	55	101	69	97	65	96	64	91	58	80	47	72	40	100	68
90.2	76	43	86	53	102	70	97	65	95	63	91	58	77	44	71	38	100	68
95.2	76	43	87	54	102	69	98	65	97	64	92	59	80	47	73	40	101	68
100.2	75	42	87	54	101	68	97	64	98	65	91	58	82	49	73	40	101	68
105.2	81	48	87	54	101	68	97	64	100	67	91	58	82	49	74	41	102	69
115.2	82	49	86	53	100	67	96	63	100	67	90	57	81	48	74	41	102	69
120.2	81	48	79	46	97	64	99	66	100	67	92	59	83	50	73	40	102	69
130.2	82	49	80	47	98	65	100	67	101	68	93	60	84	51	74	41	103	70
140.3	78	45	90	57	105	72	100	67	101	68	94	61	84	51	75	42	104	71
150.3	79	45	90	57	105	72	101	67	102	69	95	62	85	52	77	43	105	71
160.3	83	50	91	57	106	72	101	68	104	70	95	62	86	52	77	44	106	72
108.4	79	46	80	47	90	57	98	65	98	65	93	60	79	46	73	40	101	68
116.4	80	47	90	57	97	64	98	65	99	66	91	58	83	50	74	41	101	68
134.4	80	47	93	60	100	67	97	64	100	67	91	58	86	53	76	43	102	69
146.4	80	46	93	60	102	68	99	65	100	67	93	59	86	52	77	43	103	70
160.4	79	45	92	58	103	69	100	66	100	66	93	60	85	51	76	43	103	69
170.4	79	45	90	57	104	71	100	67	99	66	94	60	83	49	75	42	103	70
180.4	79	45	89	55	105	72	100	67	98	65	94	60	80	46	74	40	103	70
190.4	79	45	90	56	105	72	101	67	100	67	95	61	83	50	76	42	104	71
200.4	78	45	90	56	104	71	100	66	101	68	94	61	85	51	76	43	104	71

The acoustic data are related to standard conditions (source on a reflective surface in free field) in referable and reproducible operating conditions. The environment and the installation conditions, as well as the operating modes, can alter the sound emissions. All data with the exception of Lw_tot are provided for illustrative purposes only and can not be used for forecasting purposes or for the verification of binding limits.

Reference conditions: external air temperature 35°C; water input/output temperature from/to heat exchanger and user 12-7°C; unit operating at rated capacity, without any accessory

Lw: Values taken by measurements made in accordance with standard ISO 3744 and the Eurovent certification programme where applicable. Lw_tot is the only binding value.

Lp: Values calculated starting from noise power levels referred to a distance of 10 m from the unit; source installed on a reflective surface and in ideal free field conditions with directivity factor Q=2. No Lp value is binding.

Noise data refer to the standard conditions illustrated above, in reference and reproducible operating conditions. All data, excluding Lw_tot, are provided for the sake of exemplification and must not therefore be used for forecasting purposes or for the verification of mandatory limits. With special reference to noise emissions, the Manufacturer takes liability for their conformity, limited to the declared Lw_tot value. Any and all other Manufacturer's liability for the impact of such emissions in relation to the location of the machine and other conditions related to machine installation is excluded. Any assessment concerning these conditions falls within the area of competence of the plant designer and/or the fitter.

KAPPA REV /LN

	Octave bands [dB]																Total [dB(A)]	
	63 Hz		125 Hz		250 Hz		500 Hz		1000 Hz		2000 Hz		4000 Hz		8000 Hz		Lw tot	Lp tot
	Lw	Lp	Lw	Lp	Lw	Lp	Lw	Lp	Lw	Lp	Lw	Lp	Lw	Lp	Lw	Lp		
33.2	67	35	70	38	84	52	85	53	86	54	81	49	75	43	67	35	89	57
35.2	69	37	77	45	85	53	86	54	87	55	82	50	75	43	67	35	90	58
37.2	69	37	80	48	85	53	86	54	87	55	83	51	74	42	66	34	90	58
40.2	66	34	75	43	83	51	90	58	88	56	81	49	72	40	64	32	91	59
43.2	63	31	64	32	82	50	90	58	88	56	80	48	70	38	63	31	91	59
51.2	65	32	67	35	82	50	90	58	89	56	83	51	71	38	64	32	92	59
54.2	72	40	73	41	82	50	90	57	90	58	85	53	72	40	66	33	93	61
58.2	73	41	83	50	89	56	89	57	90	58	84	51	76	44	67	35	93	60
67.2	73	40	86	53	92	59	89	57	92	59	84	51	79	46	69	36	94	62
73.2	73	40	85	53	94	61	91	58	92	60	85	52	79	46	70	37	95	63
80.2	72	39	84	51	95	62	91	59	92	59	85	53	77	45	70	37	95	63
85.2	72	39	83	50	96	64	92	59	91	59	86	53	76	43	68	36	95	63
90.2	72	39	81	49	97	65	92	60	90	58	86	54	73	40	67	35	95	62
95.2	72	39	82	49	97	64	93	60	92	59	87	54	76	43	69	36	96	63
100.2	71	38	82	49	96	63	92	59	93	60	86	53	77	44	69	36	96	63
105.2	76	43	83	50	96	63	92	59	95	62	86	53	78	45	70	37	97	64
115.2	78	45	82	49	95	62	91	58	95	62	86	53	77	44	70	37	97	64
120.2	77	44	75	42	92	59	94	61	94	61	87	54	79	46	70	37	97	64
130.2	77	44	75	42	93	60	95	62	95	62	88	55	80	47	70	37	98	65
140.3	74	41	85	52	100	67	95	62	96	63	90	57	79	46	72	39	99	66
150.3	75	41	86	52	100	66	96	62	97	64	90	57	81	48	73	39	100	67
160.3	79	46	86	53	100	67	96	63	99	65	91	57	82	48	74	40	101	68
108.4	75	42	76	43	85	52	93	60	93	60	88	55	75	42	69	36	96	63
116.4	76	43	86	53	92	59	92	59	93	60	87	54	79	46	70	37	96	63
134.4	76	43	89	56	95	62	92	59	95	62	87	54	82	49	72	39	97	64
146.4	76	42	88	55	97	63	94	60	95	62	88	54	82	48	73	39	98	64
160.4	75	41	87	53	98	64	94	61	95	61	88	55	80	47	73	39	98	64
170.4	75	41	86	52	99	66	95	61	94	61	89	55	79	45	71	38	98	65
180.4	75	41	84	51	100	67	95	62	93	60	89	56	76	42	70	37	98	65
190.4	75	41	85	52	100	67	96	62	95	62	90	56	79	46	72	38	99	66
200.4	74	41	85	52	99	65	95	61	96	63	89	56	80	47	72	39	99	66

The acoustic data are related to standard conditions (source on a reflective surface in free field) in referable and reproducible operating conditions. The environment and the installation conditions, as well as the operating modes, can alter the sound emissions. All data with the exception of Lw_tot are provided for illustrative purposes only and can not be used for forecasting purposes or for the verification of binding limits.

Reference conditions: external air temperature 35°C; water input/output temperature from/to heat exchanger and user 12-7°C; unit operating at rated capacity, without any accessory

Lw: Values taken by measurements made in accordance with standard ISO 3744 and the Eurovent certification programme where applicable. Lw_tot is the only binding value.

Lp: Values calculated starting from noise power levels referred to a distance of 10 m from the unit; source installed on a reflective surface and in ideal free field conditions with directivity factor Q=2. No Lp value is binding.

Noise data refer to the standard conditions illustrated above, in reference and reproducible operating conditions. All data, excluding Lw_tot, are provided for the sake of exemplification and must not therefore be used for forecasting purposes or for the verification of mandatory limits. With special reference to noise emissions, the Manufacturer takes liability for their conformity, limited to the declared Lw_tot value. Any and all other Manufacturer's liability for the impact of such emissions in relation to the location of the machine and other conditions related to machine installation is excluded. Any assessment concerning these conditions falls within the area of competence of the plant designer and/or the fitter.

KAPPA REV HE

	Octave bands [dB]																Total [dB(A)]	
	63 Hz		125 Hz		250 Hz		500 Hz		1000 Hz		2000 Hz		4000 Hz		8000 Hz		Lw _{tot}	Lp _{tot}
	Lw	Lp	Lw	Lp	Lw	Lp	Lw	Lp	Lw	Lp	Lw	Lp	Lw	Lp	Lw	Lp		
33.2	71	39	74	42	89	57	90	58	91	59	86	54	79	47	71	39	94	62
35.2	73	40	82	49	90	57	91	59	92	60	87	55	79	47	72	39	95	62
37.2	73	41	84	52	90	57	91	58	92	59	88	55	79	46	71	39	95	62
40.2	70	37	79	47	88	55	95	62	93	60	86	53	76	44	69	36	96	63
43.2	67	34	68	35	86	54	95	63	93	60	85	52	74	42	67	35	96	63
51.2	68	36	71	39	87	54	95	63	94	62	88	55	76	43	69	36	97	65
54.2	76	44	77	45	87	55	95	62	95	63	90	58	77	45	71	38	98	66
58.2	77	45	87	55	94	61	94	62	95	63	89	56	81	48	72	39	98	66
67.2	77	44	90	58	97	64	94	62	97	64	88	56	83	51	73	41	99	67
73.2	77	44	90	57	99	66	96	63	97	64	90	57	83	50	74	41	100	67
80.2	76	43	88	55	100	67	97	64	97	64	90	57	82	49	74	41	100	67
85.2	76	43	87	54	101	68	97	64	96	63	91	58	80	47	73	40	100	67
90.2	76	43	86	53	102	69	97	64	95	62	91	58	78	45	72	39	100	67
95.2	76	43	87	54	102	69	98	65	97	64	92	59	81	48	73	40	101	68
100.2	75	42	87	54	101	68	97	64	98	65	91	58	82	49	74	41	101	68
105.2	81	48	87	54	101	68	97	64	100	67	91	58	82	49	75	42	102	69
115.2	82	49	86	53	100	67	96	63	100	67	90	57	82	48	75	41	102	69
120.2	81	47	79	45	97	64	99	66	100	66	92	58	84	50	74	41	102	69
80.4	73	40	82	49	91	58	98	65	96	63	89	56	79	46	72	39	99	66
86.4	70	37	71	38	90	57	99	66	97	64	89	56	78	45	71	38	100	67
102.4	72	39	75	42	91	58	99	66	98	65	92	59	79	46	73	40	101	68
108.4	79	46	80	47	90	57	98	64	98	65	93	60	80	47	74	40	101	67
116.4	81	48	91	58	98	64	99	65	100	66	92	59	85	51	76	42	102	68
134.4	81	47	94	61	101	67	98	65	101	67	92	59	87	54	77	43	103	69
146.4	80	46	93	60	102	68	99	65	100	67	93	59	86	53	77	43	103	70
160.4	79	45	91	58	103	69	100	66	100	66	93	60	85	51	77	43	103	70

The acoustic data are related to standard conditions (source on a reflective surface in free field) in referable and reproducible operating conditions. The environment and the installation conditions, as well as the operating modes, can alter the sound emissions. All data with the exception of Lw_{tot} are provided for illustrative purposes only and can not be used for forecasting purposes or for the verification of binding limits.

Reference conditions: external air temperature 35°C; water input/output temperature from/to heat exchanger and user 12-7°C; unit operating at rated capacity, without any accessory

Lw: Values taken by measurements made in accordance with standard ISO 3744 and the Eurovent certification programme where applicable. Lw_{tot} is the only binding value.

Lp: Values calculated starting from noise power levels referred to a distance of 10 m from the unit; source installed on a reflective surface and in ideal free field conditions with directivity factor Q=2. No Lp value is binding.

Noise data refer to the standard conditions illustrated above, in reference and reproducible operating conditions. All data, excluding Lw_{tot}, are provided for the sake of exemplification and must not therefore be used for forecasting purposes or for the verification of mandatory limits. With special reference to noise emissions, the Manufacturer takes liability for their conformity, limited to the declared Lw_{tot} value. Any and all other Manufacturer's liability for the impact of such emissions in relation to the location of the machine and other conditions related to machine installation is excluded. Any assessment concerning these conditions falls within the area of competence of the plant designer and/or the fitter.

KAPPA REV HE /LN

	Octave bands [dB]																Total [dB(A)]	
	63 Hz		125 Hz		250 Hz		500 Hz		1000 Hz		2000 Hz		4000 Hz		8000 Hz		Lw tot	Lp tot
	Lw	Lp	Lw	Lp	Lw	Lp	Lw	Lp	Lw	Lp	Lw	Lp	Lw	Lp	Lw	Lp		
33.2	67	35	70	38	84	52	85	53	86	54	81	49	75	43	67	35	89	57
35.2	69	36	77	45	85	52	86	54	87	54	82	50	75	42	68	35	90	58
37.2	69	37	80	47	85	52	86	53	87	54	83	50	74	42	67	35	90	58
40.2	66	34	75	42	83	51	90	57	88	55	81	49	72	40	65	33	91	59
43.2	63	30	64	31	82	49	90	58	88	55	80	48	70	38	64	31	91	59
51.2	65	32	67	35	82	50	90	58	89	56	83	51	71	39	65	33	92	59
54.2	72	40	73	41	82	50	90	57	90	58	85	53	73	41	67	34	93	61
58.2	73	41	82	50	89	56	89	57	90	58	84	51	76	44	68	36	93	60
67.2	73	40	86	53	92	59	89	57	92	59	84	51	79	46	69	37	94	62
73.2	73	40	85	52	94	61	91	58	92	59	85	52	79	46	70	37	95	62
80.2	72	39	84	51	94	61	91	58	92	59	85	52	78	45	70	37	95	62
85.2	72	39	83	50	96	63	92	59	91	58	86	53	76	43	69	36	95	62
90.2	72	39	81	48	97	64	92	59	90	57	86	53	74	41	68	35	95	62
95.2	72	39	82	49	97	64	92	59	92	59	87	54	77	44	70	37	96	63
100.2	71	38	82	49	96	63	92	59	93	60	87	54	78	45	70	37	96	63
105.2	76	43	82	49	96	63	92	59	95	62	87	54	78	45	71	38	97	64
115.2	78	45	82	48	95	62	91	58	95	62	86	52	78	44	71	37	97	64
120.2	77	43	75	41	92	59	94	61	94	61	87	54	79	46	70	37	97	64
80.4	69	36	78	45	86	53	93	60	91	58	84	51	75	42	68	35	94	61
86.4	67	34	68	35	86	53	94	61	92	59	84	51	74	41	67	34	95	62
102.4	68	35	71	38	86	53	94	61	93	60	87	54	75	42	69	36	96	63
108.4	75	42	76	43	85	52	93	59	93	60	88	55	76	43	70	36	96	62
116.4	77	44	86	53	93	59	93	60	94	61	88	54	80	47	72	38	97	63
134.4	77	43	90	56	96	62	93	60	96	62	88	54	83	49	73	40	98	65
146.4	76	42	88	55	97	63	94	60	95	62	88	55	82	48	73	40	98	65
160.4	75	41	87	53	97	64	94	61	95	61	88	55	81	47	73	39	98	65

The acoustic data are related to standard conditions (source on a reflective surface in free field) in referable and reproducible operating conditions. The environment and the installation conditions, as well as the operating modes, can alter the sound emissions. All data with the exception of Lw_tot are provided for illustrative purposes only and can not be used for forecasting purposes or for the verification of binding limits.

Reference conditions: external air temperature 35°C; water input/output temperature from/to heat exchanger and user 12-7°C; unit operating at rated capacity, without any accessory

Lw: Values taken by measurements made in accordance with standard ISO 3744 and the Eurovent certification programme where applicable. Lw_tot is the only binding value.

Lp: Values calculated starting from noise power levels referred to a distance of 10 m from the unit; source installed on a reflective surface and in ideal free field conditions with directivity factor Q=2. No Lp value is binding.

Noise data refer to the standard conditions illustrated above, in reference and reproducible operating conditions. All data, excluding Lw_tot, are provided for the sake of exemplification and must not therefore be used for forecasting purposes or for the verification of mandatory limits. With special reference to noise emissions, the Manufacturer takes liability for their conformity, limited to the declared Lw_tot value. Any and all other Manufacturer's liability for the impact of such emissions in relation to the location of the machine and other conditions related to machine installation is excluded. Any assessment concerning these conditions falls within the area of competence of the plant designer and/or the fitter.

KAPPA REV SLN

	Octave bands [dB]																Total [dB(A)]	
	63 Hz		125 Hz		250 Hz		500 Hz		1000 Hz		2000 Hz		4000 Hz		8000 Hz		Lw tot	Lp tot
	Lw	Lp	Lw	Lp	Lw	Lp	Lw	Lp	Lw	Lp	Lw	Lp	Lw	Lp	Lw	Lp		
33.2	65	33	68	36	81	49	82	50	83	51	78	46	72	40	65	33	86	54
35.2	66	34	74	42	82	49	83	51	84	51	79	47	72	40	65	33	87	55
37.2	67	34	77	44	82	49	83	50	84	51	80	48	72	39	65	32	87	54
40.2	64	31	72	40	80	48	87	54	85	52	78	46	70	37	63	30	88	56
43.2	61	28	62	29	79	46	87	55	85	52	77	45	68	36	62	29	88	56
51.2	62	30	65	33	80	47	87	54	86	53	80	48	69	37	63	30	89	57
54.2	70	37	71	38	80	47	87	54	87	55	82	50	71	38	65	32	90	58
58.2	71	38	80	47	86	53	86	54	87	55	81	48	74	41	66	33	90	58
67.2	70	38	83	50	89	56	86	54	89	56	81	48	76	44	67	34	91	59
73.2	70	37	83	50	91	58	88	55	89	56	82	49	76	43	68	35	92	59
80.2	69	36	81	48	91	58	88	55	89	56	83	50	75	42	68	35	92	59
85.2	69	36	80	47	93	60	89	56	88	55	83	50	73	40	67	34	92	59
90.2	69	36	79	46	94	61	89	56	87	54	83	50	71	38	66	33	92	59
95.2	70	37	80	47	94	61	89	56	89	56	84	51	74	41	67	34	93	60
100.2	69	36	80	47	93	60	89	56	90	57	84	51	75	42	68	35	93	60
105.2	74	41	80	47	93	60	89	56	92	59	84	51	76	43	69	36	94	61
115.2	76	42	79	46	92	59	88	55	92	59	83	49	75	42	69	35	94	61
120.2	74	41	72	39	89	56	91	58	91	58	84	51	77	43	68	34	94	61
80.4	67	34	75	42	83	50	90	57	88	55	81	48	73	40	66	33	91	58
86.4	64	31	65	32	83	50	91	58	89	56	81	48	72	39	65	32	92	59
102.4	66	33	69	36	83	50	91	58	90	57	84	51	73	40	67	34	93	60
108.4	73	39	74	40	83	49	90	56	90	57	85	52	74	40	68	34	93	59
116.4	75	41	84	50	90	56	90	57	91	58	85	51	78	44	69	36	94	60
134.4	74	41	87	53	93	59	90	57	93	59	85	51	80	46	71	37	95	62
146.4	73	40	86	52	94	60	91	57	92	59	85	52	79	46	71	37	95	62
160.4	72	39	84	51	94	61	91	58	92	58	86	52	78	45	71	37	95	62

The acoustic data are related to standard conditions (source on a reflective surface in free field) in referable and reproducible operating conditions. The environment and the installation conditions, as well as the operating modes, can alter the sound emissions. All data with the exception of Lw_tot are provided for illustrative purposes only and can not be used for forecasting purposes or for the verification of binding limits.

Reference conditions: external air temperature 35°C; water input/output temperature from/to heat exchanger and user 12-7°C; unit operating at rated capacity, without any accessory

Lw: Values taken by measurements made in accordance with standard ISO 3744 and the Eurovent certification programme where applicable. Lw_tot is the only binding value.

Lp: Values calculated starting from noise power levels referred to a distance of 10 m from the unit; source installed on a reflective surface and in ideal free field conditions with directivity factor Q=2. No Lp value is binding.

Noise data refer to the standard conditions illustrated above, in reference and reproducible operating conditions. All data, excluding Lw_tot, are provided for the sake of exemplification and must not therefore be used for forecasting purposes or for the verification of mandatory limits. With special reference to noise emissions, the Manufacturer takes liability for their conformity, limited to the declared Lw_tot value. Any and all other Manufacturer's liability for the impact of such emissions in relation to the location of the machine and other conditions related to machine installation is excluded. Any assessment concerning these conditions falls within the area of competence of the plant designer and/or the fitter.

CONFIGURATIONS THAT ARE NOT POSSIBLE

KAPPA REV

	CHILLER ONLY									HEAT PUMP					
	Basic	/1P /2P	/1PS /2PS	DS	/DS /1P /DS /2P	/DS /1PS /DS /2PS	DC	/DC /1P /DC /2P	/DC /1PS /DC /2PS	HP	HP/1P HP/2P	HP/1PS HP/2PS	HP/DS	HP/1P/DS HP/2P/DS	HP/1PS/DS HP/2PS/DS
33.2			n.a.		n.a.	n.a.		n.a.	n.a.		n.a.	n.a.	n.a.	n.a.	n.a.
35.2			n.a.		n.a.	n.a.		n.a.	n.a.		n.a.	n.a.	n.a.	n.a.	n.a.
37.2			n.a.		n.a.	n.a.		n.a.	n.a.		n.a.	n.a.	n.a.	n.a.	n.a.
40.2			n.a.		n.a.	n.a.		n.a.	n.a.		n.a.	n.a.	n.a.	n.a.	n.a.
43.2			n.a.		n.a.	n.a.		n.a.	n.a.		n.a.	n.a.	n.a.	n.a.	n.a.
51.2						n.a.		n.a.	n.a.		n.a.	n.a.	n.a.	n.a.	n.a.
54.2						n.a.		n.a.	n.a.		n.a.	n.a.	n.a.	n.a.	n.a.
58.2						n.a.		n.a.	n.a.			n.a.	n.a.	n.a.	n.a.
67.2						n.a.		n.a.	n.a.			n.a.	n.a.	n.a.	n.a.
73.2						n.a.			n.a.			n.a.		n.a.	n.a.
80.2						n.a.			n.a.			n.a.		n.a.	n.a.
85.2						n.a.			n.a.			n.a.		n.a.	n.a.
90.2						n.a.			n.a.			n.a.		n.a.	n.a.
95.2						n.a.			n.a.			n.a.		n.a.	n.a.
100.2						n.a.			n.a.			n.a.		n.a.	n.a.
105.2						n.a.			n.a.	n.a.	n.a.	n.a.	n.a.	n.a.	n.a.
115.2						n.a.	n.a.	n.a.	n.a.	n.a.	n.a.	n.a.	n.a.	n.a.	n.a.
120.2						n.a.	n.a.	n.a.	n.a.	n.a.	n.a.	n.a.	n.a.	n.a.	n.a.
130.2						n.a.	n.a.	n.a.	n.a.	n.a.	n.a.	n.a.	n.a.	n.a.	n.a.
140.3			n.a.	n.a.	n.a.	n.a.	n.a.	n.a.	n.a.	n.a.	n.a.	n.a.	n.a.	n.a.	n.a.
150.3			n.a.	n.a.	n.a.	n.a.	n.a.	n.a.	n.a.	n.a.	n.a.	n.a.	n.a.	n.a.	n.a.
160.3			n.a.	n.a.	n.a.	n.a.	n.a.	n.a.	n.a.	n.a.	n.a.	n.a.	n.a.	n.a.	n.a.
108.4	n.a.	n.a.	n.a.	n.a.	n.a.	n.a.	n.a.	n.a.	n.a.		n.a.	n.a.	n.a.	n.a.	n.a.
116.4	n.a.	n.a.	n.a.	n.a.	n.a.	n.a.	n.a.	n.a.	n.a.			n.a.	n.a.	n.a.	n.a.
134.4	n.a.	n.a.	n.a.	n.a.	n.a.	n.a.	n.a.	n.a.	n.a.			n.a.	n.a.	n.a.	n.a.
146.4	n.a.	n.a.	n.a.	n.a.	n.a.	n.a.	n.a.	n.a.	n.a.			n.a.		n.a.	n.a.
160.4	n.a.	n.a.	n.a.	n.a.	n.a.	n.a.	n.a.	n.a.	n.a.			n.a.		n.a.	n.a.
170.4						n.a.			n.a.			n.a.		n.a.	n.a.
180.4						n.a.			n.a.			n.a.		n.a.	n.a.
190.4						n.a.			n.a.			n.a.		n.a.	n.a.
200.4						n.a.			n.a.			n.a.		n.a.	n.a.

KAPPA REV HE - KAPPA REV SLN

	CHILLER ONLY									HEAT PUMP					
	Basic	/1P /2P	/1PS /2PS	DS	/DS /1P /DS /2P	/DS /1PS /DS /2PS	DC	/DC /1P /DC /2P	/DC /1PS /DC /2PS	HP	HP/1P HP/2P	HP/1PS HP/2PS	HP/DS	HP/1P/DS HP/2P/DS	HP/1PS/DS HP/2PS/DS
33.2			n.a.		n.a.	n.a.		n.a.	n.a.		n.a.	n.a.	n.a.	n.a.	n.a.
35.2						n.a.		n.a.	n.a.		n.a.	n.a.	n.a.	n.a.	n.a.
37.2						n.a.		n.a.	n.a.		n.a.	n.a.	n.a.	n.a.	n.a.
40.2						n.a.		n.a.	n.a.		n.a.	n.a.	n.a.	n.a.	n.a.
43.2						n.a.		n.a.	n.a.		n.a.	n.a.	n.a.	n.a.	n.a.
51.2						n.a.		n.a.	n.a.			n.a.	n.a.	n.a.	n.a.
54.2						n.a.		n.a.	n.a.			n.a.		n.a.	n.a.
58.2						n.a.			n.a.			n.a.		n.a.	n.a.
67.2						n.a.			n.a.			n.a.		n.a.	n.a.
73.2						n.a.			n.a.			n.a.		n.a.	n.a.
80.2						n.a.			n.a.			n.a.		n.a.	n.a.
85.2						n.a.			n.a.	n.a.	n.a.	n.a.	n.a.	n.a.	n.a.
90.2						n.a.			n.a.	n.a.	n.a.	n.a.	n.a.	n.a.	n.a.
95.2						n.a.			n.a.	n.a.	n.a.	n.a.	n.a.	n.a.	n.a.
100.2						n.a.			n.a.	n.a.	n.a.	n.a.	n.a.	n.a.	n.a.
105.2						n.a.			n.a.	n.a.	n.a.	n.a.	n.a.	n.a.	n.a.
115.2						n.a.	n.a.	n.a.	n.a.	n.a.	n.a.	n.a.	n.a.	n.a.	n.a.
120.2						n.a.	n.a.	n.a.	n.a.	n.a.	n.a.	n.a.	n.a.	n.a.	n.a.
80.4	n.a.	n.a.	n.a.	n.a.	n.a.	n.a.	n.a.	n.a.	n.a.		n.a.	n.a.	n.a.	n.a.	n.a.
86.4	n.a.	n.a.	n.a.	n.a.	n.a.	n.a.	n.a.	n.a.	n.a.		n.a.	n.a.	n.a.	n.a.	n.a.
102.4	n.a.	n.a.	n.a.	n.a.	n.a.	n.a.	n.a.	n.a.	n.a.			n.a.	n.a.	n.a.	n.a.
108.4	n.a.	n.a.	n.a.	n.a.	n.a.	n.a.	n.a.	n.a.	n.a.			n.a.		n.a.	n.a.
116.4	n.a.	n.a.	n.a.	n.a.	n.a.	n.a.	n.a.	n.a.	n.a.			n.a.		n.a.	n.a.
134.4						n.a.			n.a.			n.a.		n.a.	n.a.
146.4						n.a.			n.a.			n.a.		n.a.	n.a.
160.4						n.a.			n.a.			n.a.		n.a.	n.a.

INSTALLATION ADVICE

The units described in this document are, by nature, strongly affected by the characteristics of the system, the working conditions and the installation site.

Remember that the unit must be installed by a qualified and skilled technician, and in compliance with the national legislation in force in the destination country.

The installation must be done in such a way that it will be possible to carry out all routine and non-routine maintenance operations.

Before starting any work, you must carefully read the "Installation, operation and maintenance manual" of the machine and do the necessary safety checks to prevent any malfunctioning or hazards.

We give some advice below that will allow you to increase the efficiency and reliability of the unit and therefore of the system into which it is inserted.

Water characteristics

To preserve the life of the exchangers, the water is required to comply with some quality parameters and it is therefore necessary to make sure its values fall within the ranges indicated in the following table:

Total hardness	2,0 ÷ 6,0 °f
Langelier index	- 0,4 ÷ 0,4
pH	7,5 ÷ 8,5
Electrical conductivity	10 ÷ 500 µS/cm
Organic elements	-
Hydrogen carbonate (HCO₃⁻)	70 ÷ 300 ppm
Sulphates (SO₄²⁻)	< 50 ppm
Hydrogen carbonate / Sulphates (HCO₃⁻/SO₄²⁻)	> 1
Chlorides (Cl⁻)	< 50 ppm
Nitrates (NO₃⁻)	< 50 ppm
Hydrogen sulphide (H₂S)	< 0,05 ppm
Ammonia (NH₃)	< 0,05 ppm
Sulphites (SO₃), free chlorine (Cl₂)	< 1 ppm
Carbon dioxide (CO₂)	< 5 ppm
Metal cations	< 0,2 ppm
Manganese ions (Mn⁺⁺)	< 0,2 ppm
Iron ions (Fe²⁺ , Fe³⁺)	< 0,2 ppm
Iron + Manganese	< 0,4 ppm
Phosphates (PO₄³⁻)	< 2 ppm
Oxygen	< 0,1 ppm

Installation of water filters on all the hydraulic circuits is obligatory.

The supply of the most suitable filters for the unit can be requested as accessory. In this case, the filters are supplied loose and must be installed by the customer following the instructions given in the installation, operation and maintenance manual.

Glycol mixtures

With temperatures below 5°C, it is mandatory to work with water and anti-freeze mixtures, and also change the safety devices (anti-freeze, etc.), which must be carried out by qualified authorised personnel or by the manufacturer.

Liquid outlet temperature or minimum ambient temperature	°C	0	-5	-10	-15	-20	-25	-30	-35	-40
Freezing point	°C	-5	-10	-15	-20	-25	-30	-35	-40	-45
Ethylene glycol	%	6	22	30	36	41	46	50	53	56
Propylene glycol	%	15	25	33	39	44	48	51	54	57

The quantity of antifreeze should be considered as % on weight

Minimum water content in the system

For correct operation of the unit, it is necessary to ensure a buffering on the system such as to comply with the minimum operating time considering the greater between the minimum OFF time and the minimum ON time. In short, these contribute to limiting the number of times the compressors are switched on per hour and to preventing undesired deviations from the set point of the delivered water temperature.

Larger amounts of water are in any case always preferable, because they allow a smaller number of starts and switch-offs of the compressors, less wear of them and an increase in the efficiency of the system as a consequence of a reduction in the number of transients.

It should also be pointed out that, for air-water units working in heat pump mode, the minimum amount of water must consider the need of the unit to carry out defrosting. Having an adequate buffering volume will allow prevention of too high drifts of the delivered water temperature at the end of the defrost cycle.

The following experimental formula allows to calculate the minimum water volume of the plant. The formula refers only to the operation of the unit in cooling mode.

$$V_{min} = \frac{P_{tot} \cdot 1.000}{N} \cdot \frac{300}{\Delta T \cdot \rho \cdot c_p} + P_{tot} \cdot 0,8$$

where

V_{min} is the minimum water content of the system [l]

P_{tot} is the total cooling capacity of the machine [kW]

N: number of capacity reduction steps

ΔT : differential allowed on the water temperature. Unless otherwise specified, this value is considered to be 2.5K

ρ : density of the heat-carrying fluid. Unless otherwise specified, the density of water is considered

c_p : specific heat of the heat-carrying fluid. Unless otherwise specified, the specific heat of water is considered

Considering the use of water and grouping together some terms, the formula can be re-written as follows:

$$V_{min} = \frac{P_{tot}}{N} \cdot 28,66 + P_{tot} \cdot 0,8$$

For the N values, consider the following convention:

- for units with 1 compressor N = 4
- for units with 2 compressors N = 8
- for units with 3 compressors N = 12
- for units with 4 compressors N = 16

Installation site

To determine the best installation site for the unit and its orientation, you should pay attention to the following points:

- compliance with the clearance spaces indicated in the official dimensional drawing of the unit must be guaranteed so as to ensure accessibility for routine and non-routine maintenance operations
- you should consider the origin of the hydraulic pipes and their diameters because these affect the radiuses of curvature and therefore the spaces needed for installing them
- you should consider the position of the cable inlet on the electrical control panel of the unit as regards the origin of the power supply
- if the installation includes several units side by side, you should consider the position and dimensions of the manifolds of the user-side exchangers and of any recovery exchangers
- if the installation includes several units side by side, you should consider that the minimum distance between units is 3 metres
- you should avoid all obstructions that can limit air circulation to the source-side exchanger or that can cause recirculation between air supply and intake
- you should consider the orientation of the unit to limit, as far as possible, exposure of the source-side exchanger to solar radiation
- if the installation area is particularly windy, the orientation and positioning of the unit must be such as to avoid air recirculation on the coils. If necessary, we advise making windbreak barriers in order to prevent malfunctioning.

Once the best position for the unit has been identified, you must check that the support slab has the following characteristics:

- its dimensions must be proportionate to those of the unit: if possible, longer and wider than the unit by at least 30 cm and 15/20cm higher than the surrounding surface
- it must be able to bear at least 4 times the operating weight of the unit
- it must allow level installation of the unit: although the unit is installed on a horizontal base, make slopes in the support surface to convey rain water or defrost water to drains, wells or in any case to places where it cannot generate an accident hazard due to ice formation. All heat pump version units are equipped with discharge manifolds for the condensed water; these can be manifolded to facilitate condensate discharge.

The units are designed and built to reduce to a minimum the level of vibration transmitted to the ground, but it is in any case advisable to use rubber or spring anti-vibration mounts, which are available as accessory and should be requested when ordering.

The anti-vibration mounts must be fixed on before positioning the unit on the ground.

In the event of installation on roofs or intermediate floors, the pipes must be isolated from the walls and ceilings.

It is advisable to avoid installation in cramped places, to prevent reverberations, reflections, resonances and acoustic interactions with elements outside the unit.

It is essential that any work done to soundproof the unit does not affect its correct installation or correct operation and, in particular, does not reduce the air flow rate to the source-side exchanger.

Installations that require the use of treated coils

If the unit has to be installed in an environment with a particularly aggressive atmosphere, coils with special treatments are available as options.

- e-coated microchannel coils (accessory not available for HP units)
- pre-painted aluminium coils (accessory available only for HP units)
- coils with anti-corrosion treatment (accessory available only for units with Cu/Al coil or HP units)

A description of the individual accessories is available in the "Description of accessories" section.

The type of coil treatment should be chosen with regard to the environment in which the unit is to be installed, through observation of other structures and machinery with exposed metal surfaces present in the destination environment.

The cross observation criterion is the most valid method of selection currently available without having to carry out preliminary tests or measurements with instruments. The identified reference environments are:

- coastal/marine
- industrial
- urban with a high housing density
- rural

Please note that in cases where different conditions co-exist, even for short periods, the choice must be suitable for preserving the exchanger in the harsher environmental conditions and not in conditions between the worst and best situation.

Particular attention must be given in cases where an environment that is not particularly aggressive becomes aggressive as a consequence of a concomitant cause, for example, the presence of a flue outlet or an extraction fan.

We strongly suggest choosing one of the treatment options if at least one of the points listed below is verified:

- there are obvious signs of corrosion of the exposed metal surfaces in the installation area
- the prevailing winds come from the sea towards the unit
- the environment is industrial with a significant concentration of pollutants
- the environment is urban with a high population density
- the environment is rural with the presence of organic discharges and effluents

In particular, for installations near the coast, the following instructions apply:

- for installations between 1 and 20 km from the coast of units with microchannel coil, we strongly recommend using the accessory "E-coated microchannel coils"
- for installations between 1 and 20 km from the coast of reversible units or units with Cu/Al coils, we strongly recommend using the accessory "Coil treated with anti-corrosion paints"
- for distances within a kilometre of the coast, we strongly recommend using the accessory "Coil treated with anti-corrosion paints" for all units.

To protect the exchangers from corrosion and ensure optimal operation of the unit, we advise following the recommendations given in the user, installation and maintenance manual for cleaning the coils.

Aeraulic head losses and options available for the ventilating section

With the exception of units for which oversize fans are required, as standard, the units are designed considering that, at the nominal air flow rate, the fans work with null available pressure.

If there are obstacles to free air flow, you should consider the additional aeraulic head losses that will cause a reduction of the air flow rate and a consequent deterioration of performance.

The following diagrams show the trend of cooling capacity (PC), EER, total absorbed power (Pabs) and reduction of the maximum external air temperature in chiller operating mode, depending on the aeraulic head losses that the fans will have to overcome.

AC fans (Ø 800)

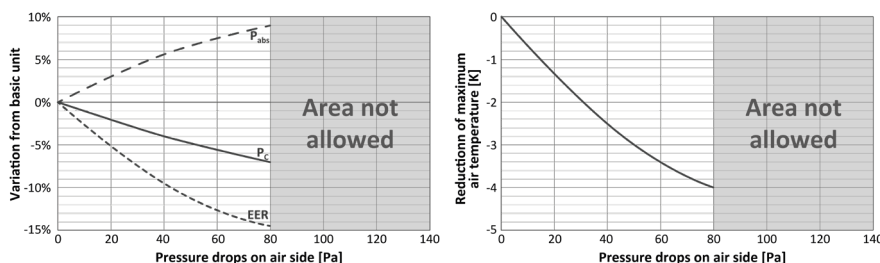

EC fans (Ø 800)

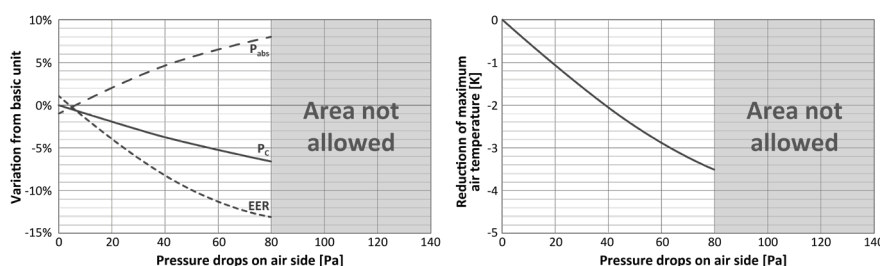

Oversize EC fans (Ø 800)

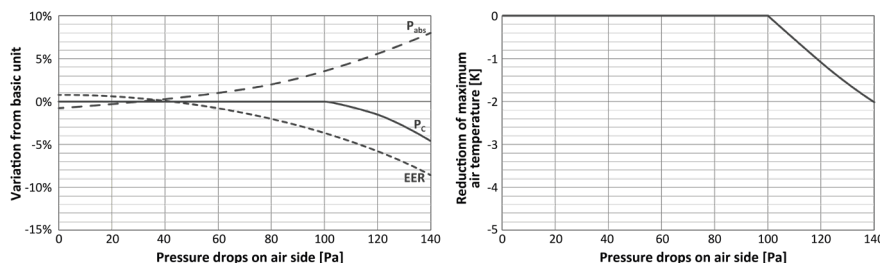

The indicated values are for the standard machine, without accessories, with AC fans and in any case in the absence of air recirculation.

Example: supposing you expect there to be obstacles that will generate an estimated aeraulic head loss of 60Pa. In this case, there are 3 possibilities:

- use the unit with standard AC fans: compared to ideal conditions, the output power will be reduced by about 5.5%, the total absorbed power will increase by about 7.5%, the EER will be reduced by about 12.5% and the maximum allowed external air temperature for operation at 100% will be reduced by about 3.4K compared to the nominal limit
- use the unit with EC fans: compared to the unit with AC fans working in ideal conditions, the output power will be reduced by about 5%, the total absorbed power will increase by about 6.5%, the EER will be reduced by about 11.5% and the maximum allowed external air temperature for operation at 100% will be reduced by about 2.8K compared to the nominal limit
- use the unit with oversize EC fans: compared to the unit with AC fans working in ideal conditions, the output power of the unit will be unchanged, the total absorbed power will increase by about 1%, the EER will be reduced by about 2% and the maximum external air temperature will remain the one shown in the diagram of the operating limits.

DIMENSIONAL DIAGRAMS

KAPPA REV 33.2 - 160.3

A4F256A

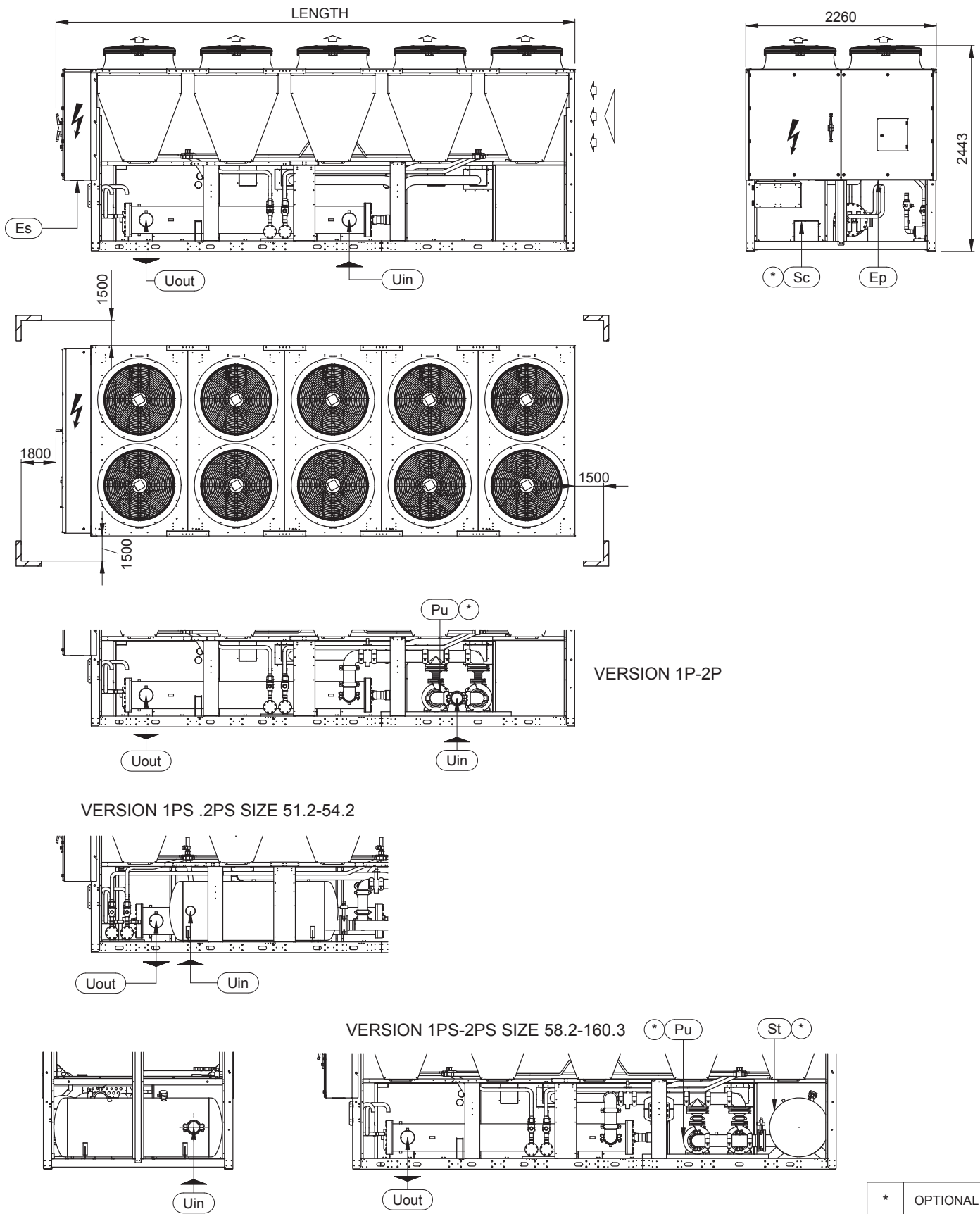

VERSION 1P-2P

VERSION 1PS .2PS SIZE 51.2-54.2

VERSION 1PS-2PS SIZE 58.2-160.3

*	OPTIONAL
---	----------

Note: These drawings are not contractually binding. For the installation design, refer to the specific dimensional drawing available on request.

Size	LENGHT	Uin (ST)	Uin 1P-2P	Uin 1PS-2PS	Uout
33.2	3870	OD 114.3	OD 114.3	-	OD 114.3
35.2	3870	OD 114.3	OD 114.3	-	OD 114.3
37.2	3870	OD 114.3	OD 114.3	-	OD 114.3
40.2	3870	OD 114.3	OD 114.3	-	OD 114.3
43.2	3870	OD 139.7	OD 114.3	-	OD 139.7
51.2	5020	OD 139.7	OD 114.3	OD 114.3	OD 139.7
54.2	5020	OD 139.7	OD 114.3	OD 114.3	OD 139.7
58.2	6170	OD 139.7	OD 139.7	OD 139.7	OD 139.7
67.2	6170	OD 168.3	OD 139.7	OD 139.7	OD 168.3
73.2	7310	OD 168.3	OD 139.7	OD 139.7	OD 168.3
80.2	7310	OD 168.3	OD 139.7	OD 139.7	OD 168.3
85.2	7310	OD 168.3	OD 139.7	OD 139.7	OD 168.3
90.2	7310	OD 168.3	OD 139.7	OD 139.7	OD 168.3
95.2	8465	OD 219.1	OD 168.3	OD 168.3	OD 219.1
100.2	8465	OD 219.1	OD 168.3	OD 168.3	OD 219.1
105.2	9610	OD 219.1	OD 168.3	OD 168.3	OD 219.1
115.2	9610	OD 219.1	OD 168.3	OD 168.3	OD 219.1
120.2	10760	OD 219.1	OD 168.3	OD 168.3	OD 219.1
130.2	10760	OD 219.1	OD 168.3	OD 168.3	OD 219.1
140.3	11970	OD 273.0	OD 219.1	-	OD 273.0
150.3	13110	OD 273.0	OD 219.1	-	OD 273.0
160.3	13110	OD 273.0	OD 219.1	-	OD 273.0

Note: These drawings are not contractually binding. For the installation design, refer to the specific dimensional drawing available on request.

KAPPA REV HE / KAPPA REV SLN 33.2 - 120.2

A4F257A

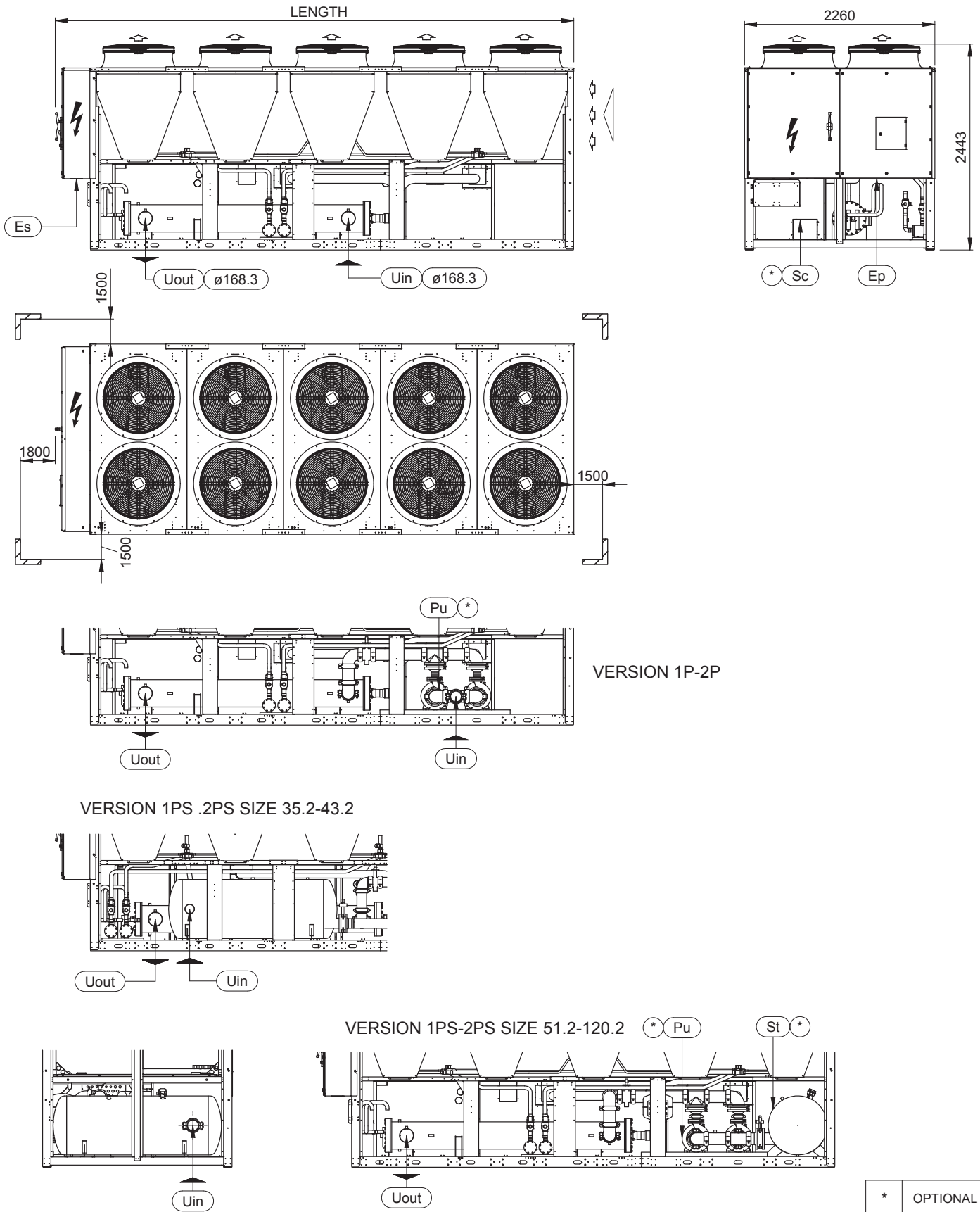

*	OPTIONAL
---	----------

Note: These drawings are not contractually binding. For the installation design, refer to the specific dimensional drawing available on request.

Size	LENGTH	Uin(ST)	Uin 1P-2P	Uin 1PS-2PS	Uout
33.2	3870	OD 114.3	OD 114.3	-	OD 114.3
35.2	5020	OD 139.7	OD 114.3	OD 114.3	OD 139.7
37.2	5020	OD 139.7	OD 114.3	OD 114.3	OD 139.7
40.2	5020	OD 139.7	OD 114.3	OD 114.3	OD 139.7
43.2	5020	OD 139.7	OD 114.3	OD 114.3	OD 139.7
51.2	6170	OD 139.7	OD 114.3	OD 114.3	OD 139.7
54.2	7310	OD 139.7	OD 114.3	OD 114.3	OD 139.7
58.2	7310	OD 168.3	OD 114.3	OD 114.3	OD 168.3
67.2	7310	OD 168.3	OD 139.7	OD 139.7	OD 168.3
73.2	8465	OD 168.3	OD 139.7	OD 139.7	OD 168.3
80.2	8465	OD 168.3	OD 139.7	OD 139.7	OD 168.3
85.2	9610	OD 219.1	OD 139.7	OD 139.7	OD 219.1
90.2	9610	OD 219.1	OD 139.7	OD 139.7	OD 219.1
95.2	10760	OD 219.1	OD 168.3	OD 168.3	OD 219.1
100.2	10760	OD 219.1	OD 168.3	OD 168.3	OD 219.1
105.2	11970	OD 219.1	OD 168.3	OD 168.3	OD 219.1
115.2	13110	OD 219.1	OD 168.3	OD 168.3	OD 219.1
120.2	13110	OD 219.1	OD 168.3	OD 168.3	OD 219.1

Note: These drawings are not contractually binding. For the installation design, refer to the specific dimensional drawing available on request.



TC-0000-KR-EN-Rev08-20201124

